

1A

UNIT TYPE: 1 BEDROOM
 SUITE AREA: 492 sq.ft.
 OUTDOOR AREA: 135 sq.ft.
 TOTAL AREA: 627 sq.ft.

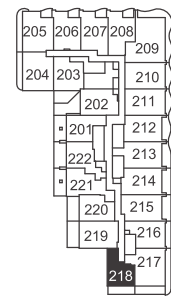

Level 2

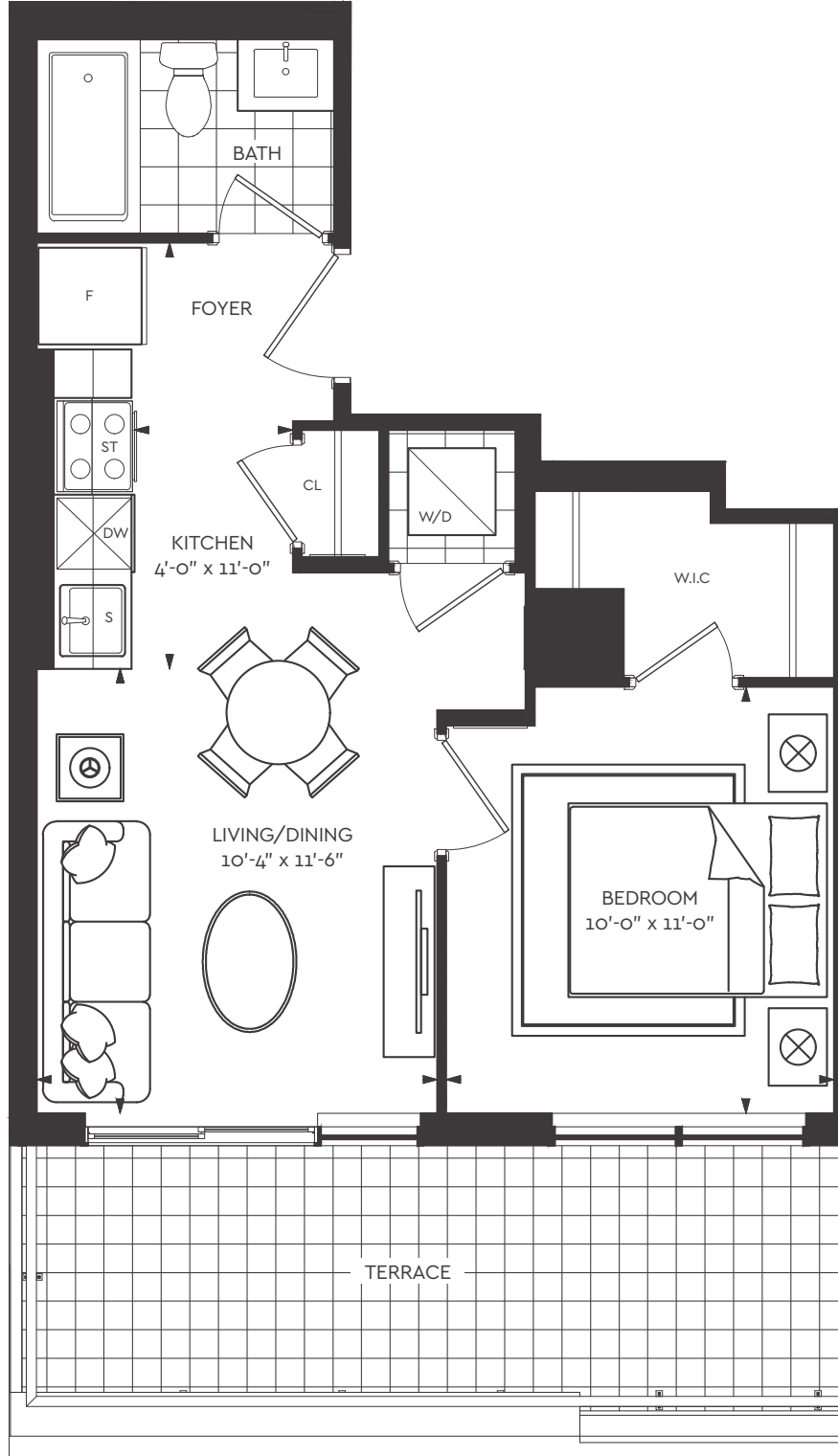

1B

UNIT TYPE: 1 BEDROOM
 SUITE AREA: 556 sq.ft.
 OUTDOOR AREA: 105-192 sq.ft.
 TOTAL AREA: 661-748 sq.ft.

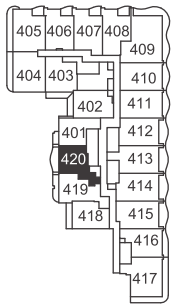
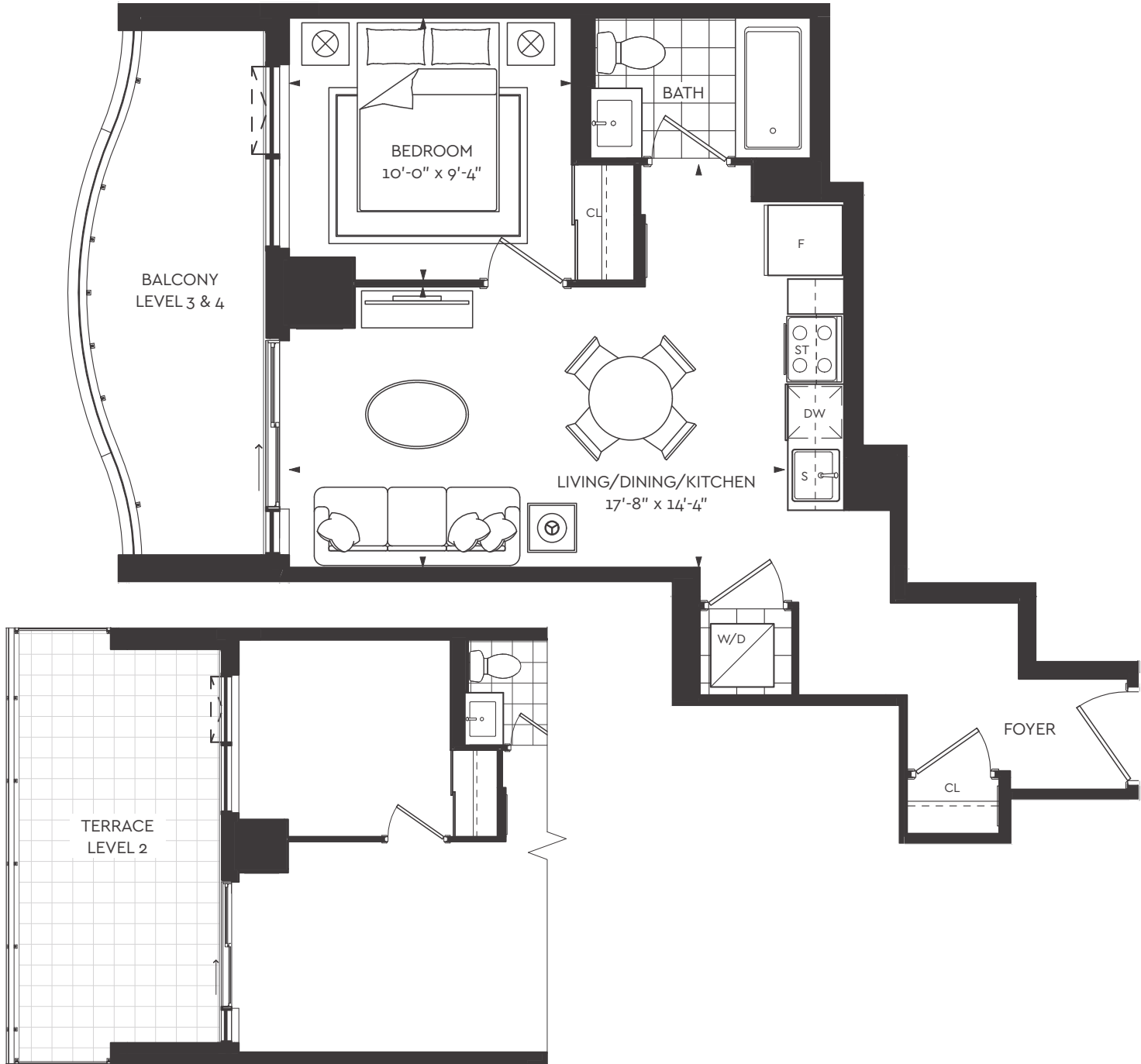

Level 4

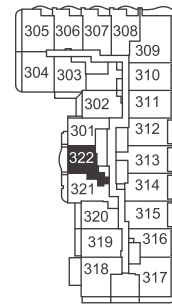

Level 3

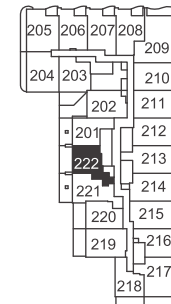

Level 2



1C

UNIT TYPE: 1 BEDROOM
 SUITE AREA: 517 sq.ft.
 OUTDOOR AREA: 49-193 sq.ft.
 TOTAL AREA: 566-710 sq.ft.

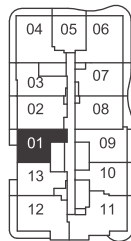
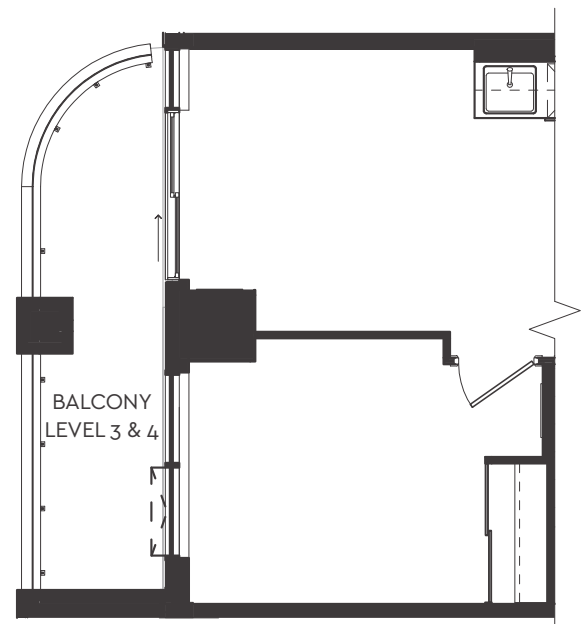
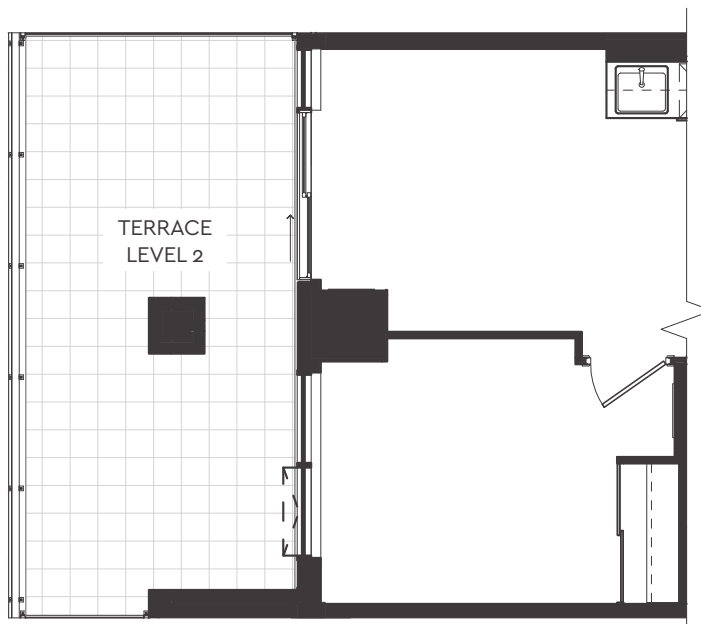
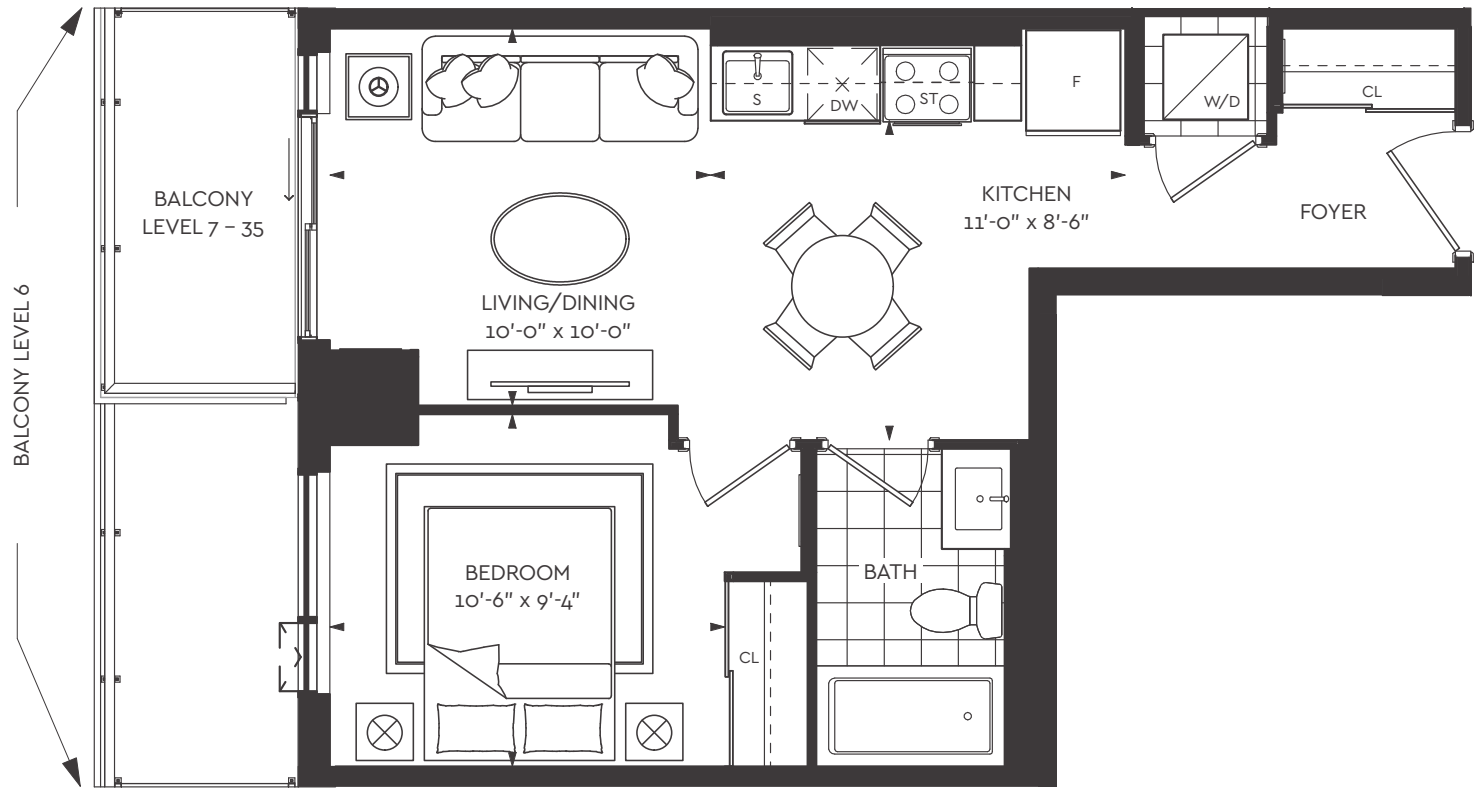

Level 7-35

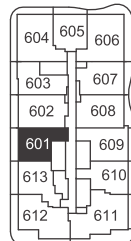

Level 6

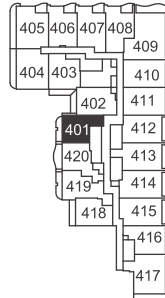

Level 4

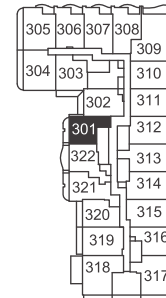

Level 3

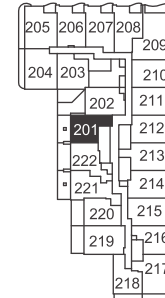

Level 2



1D

UNIT TYPE: 1 BEDROOM
 SUITE AREA: 516 sq.ft.
 OUTDOOR AREA: 94 sq.ft.
 TOTAL AREA: 610 sq.ft.

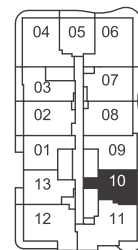
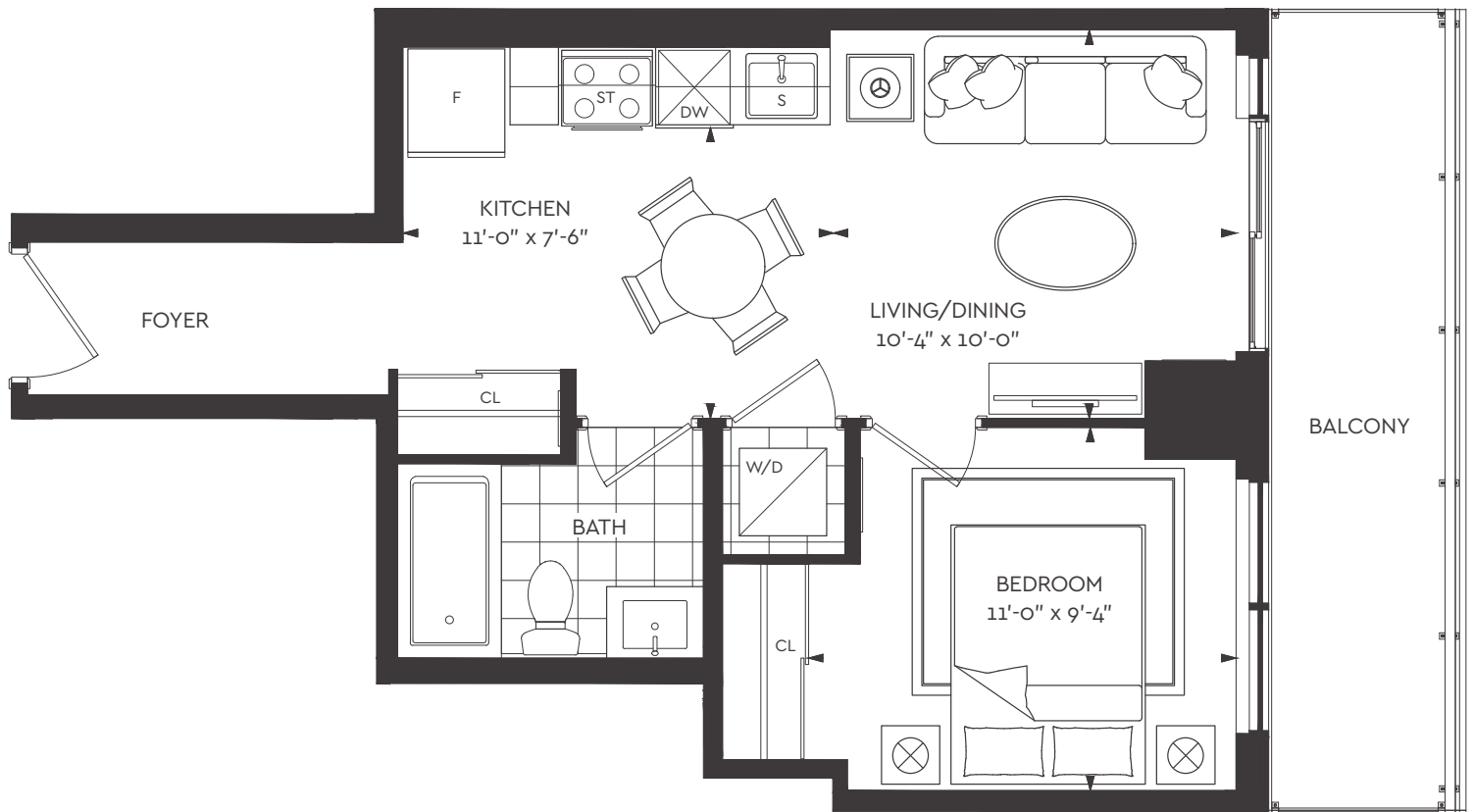

Level 7-35

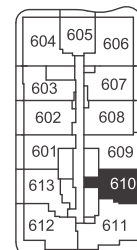

Level 6



1E

UNIT TYPE: 1 BEDROOM
 SUITE AREA: 539 sq.ft.
 OUTDOOR AREA: 101 sq.ft.
 TOTAL AREA: 640 sq.ft.

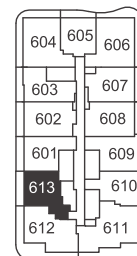
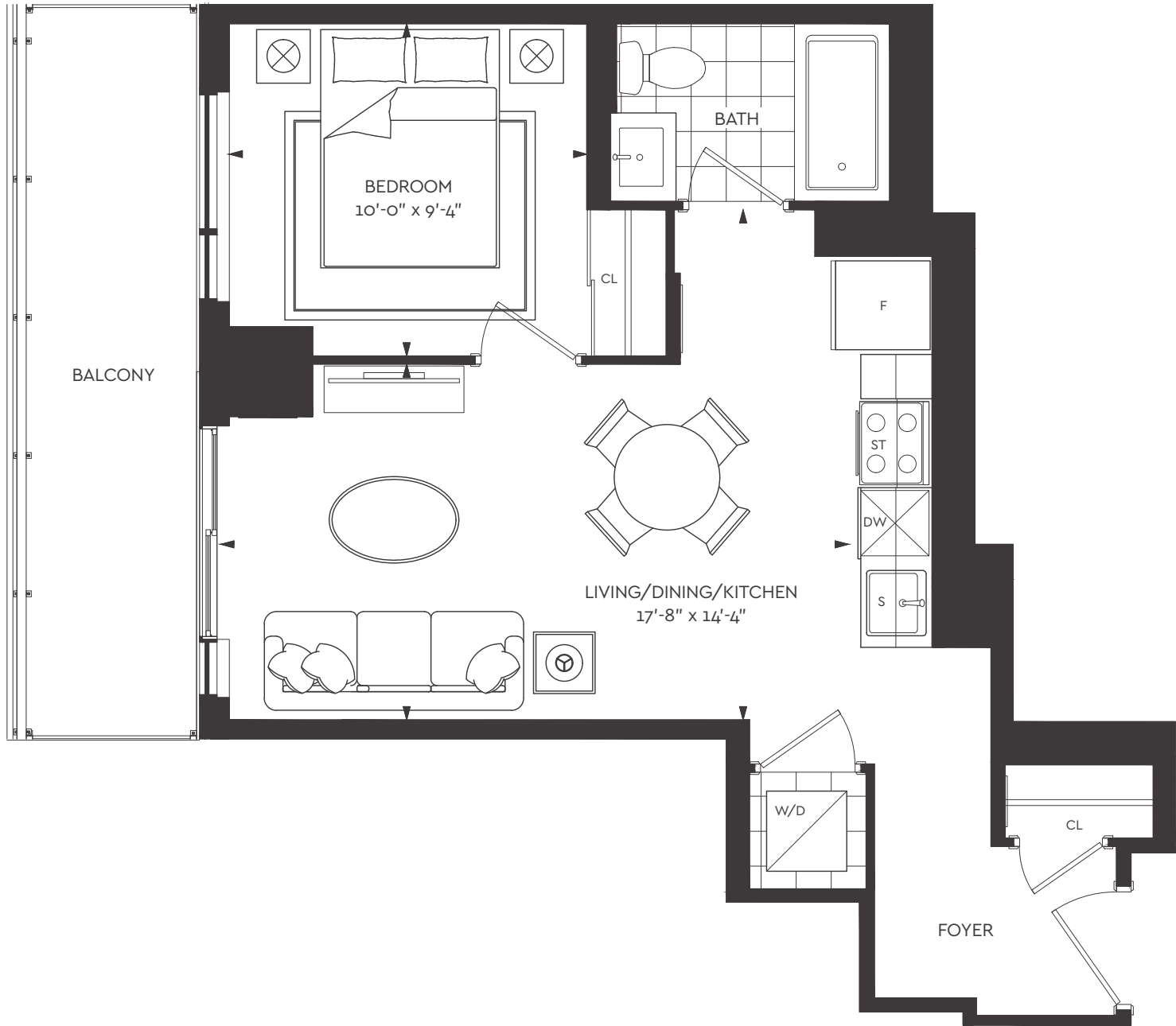

Level 6



1F

UNIT TYPE: 1 BEDROOM
 SUITE AREA: 502 sq.ft.
 OUTDOOR AREA: 94 sq.ft.
 TOTAL AREA: 596 sq.ft.

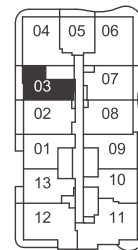
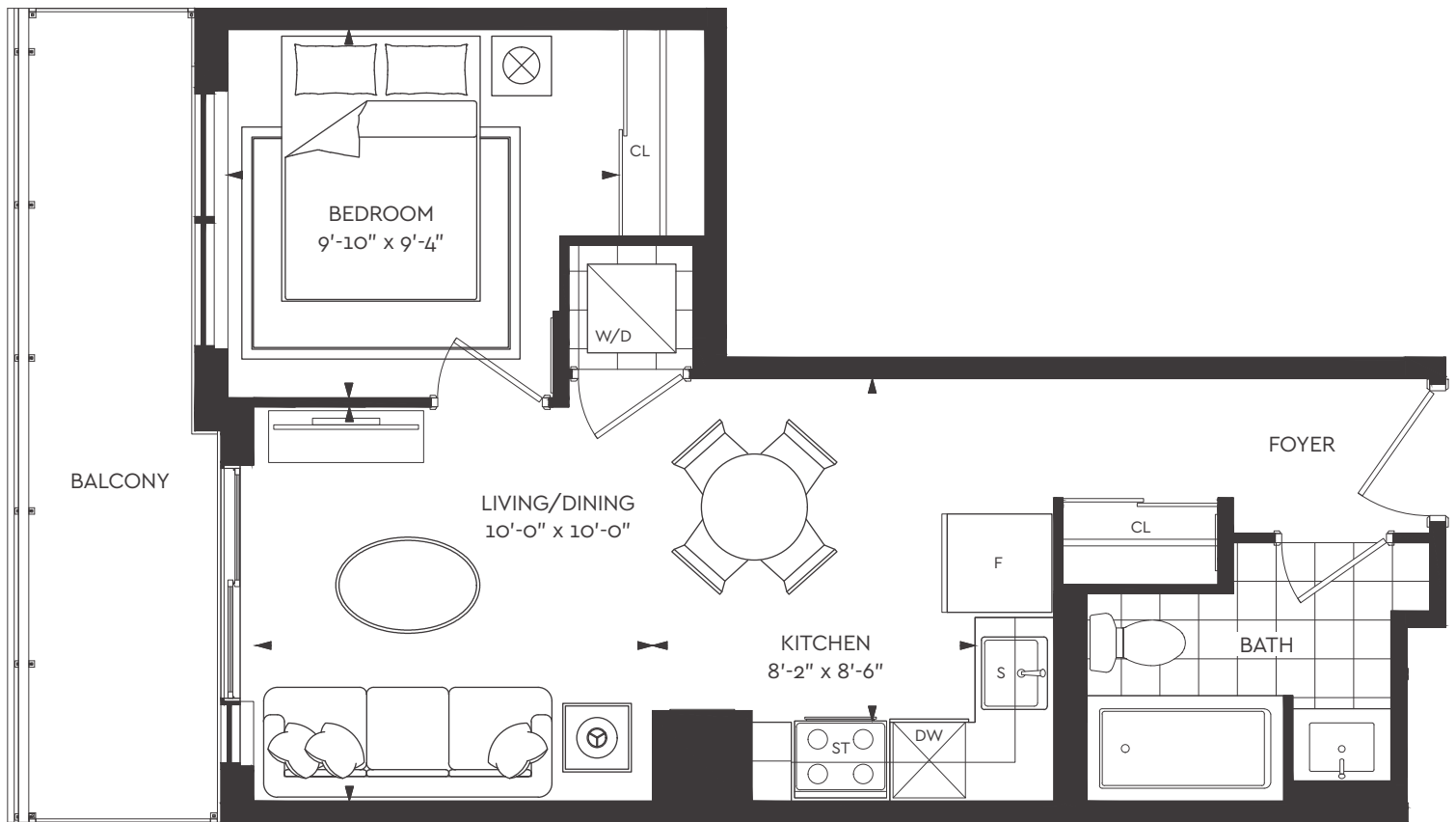

Level 7-35

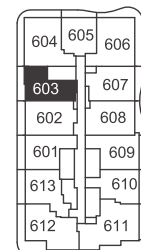

Level 6



1G

UNIT TYPE: 1 BEDROOM
 SUITE AREA: 469 sq.ft.
 OUTDOOR AREA: 89-100 sq.ft.
 TOTAL AREA: 558-569 sq.ft.

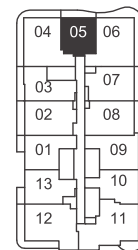
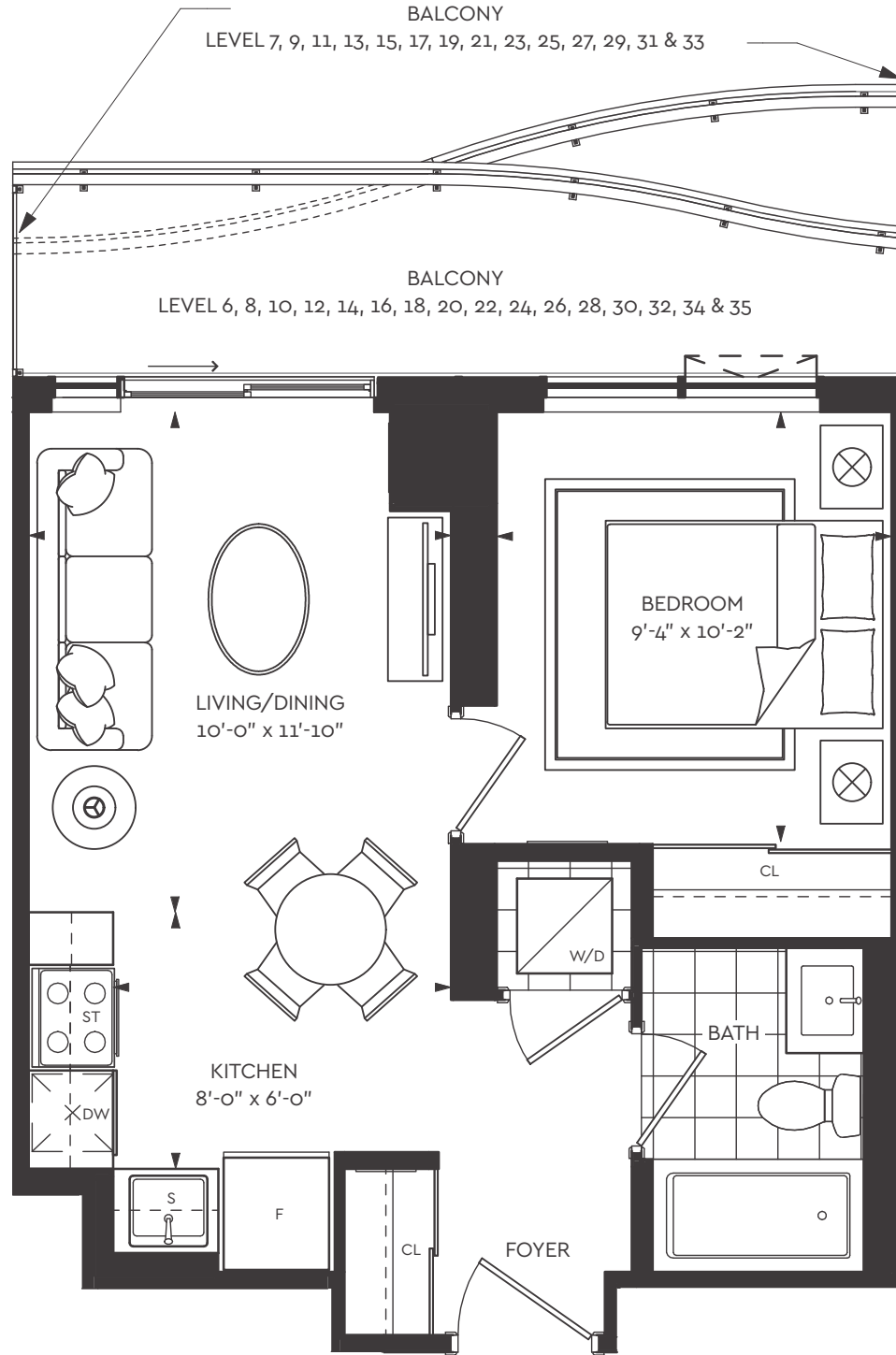

Level 7-35

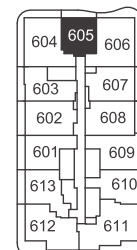

Level 6



1H

UNIT TYPE: 1 BEDROOM
 SUITE AREA: 546 sq.ft.
 OUTDOOR AREA: 49 sq.ft.
 TOTAL AREA: 595 sq.ft.

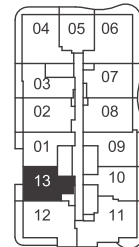
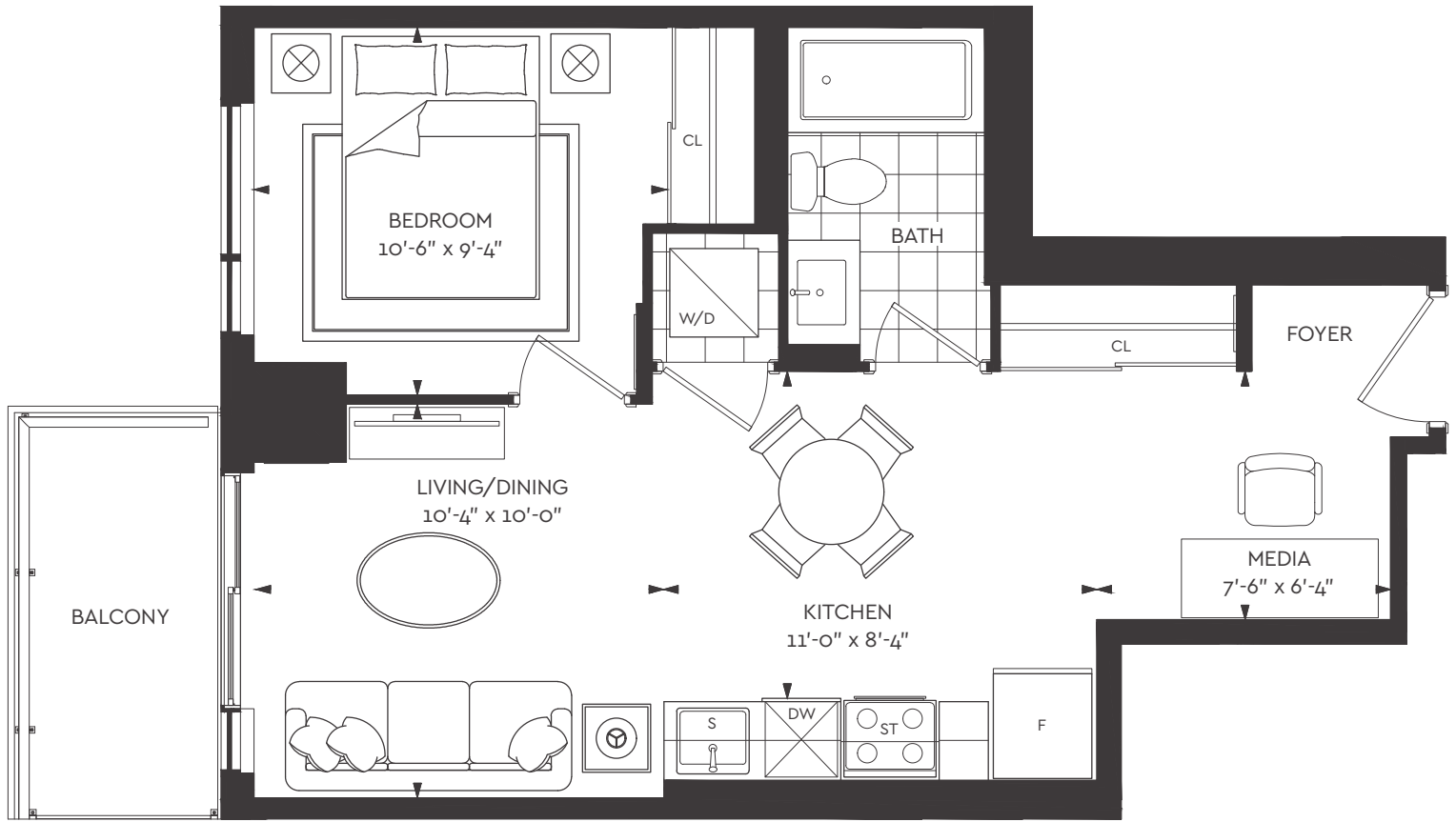

Level 7-35



1A+D

UNIT TYPE: 1 BEDROOM + DEN
 SUITE AREA: 638 sq.ft.
 OUTDOOR AREA: 144 sq.ft.
 TOTAL AREA: 782 sq.ft.

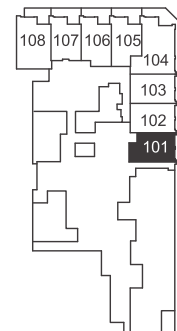
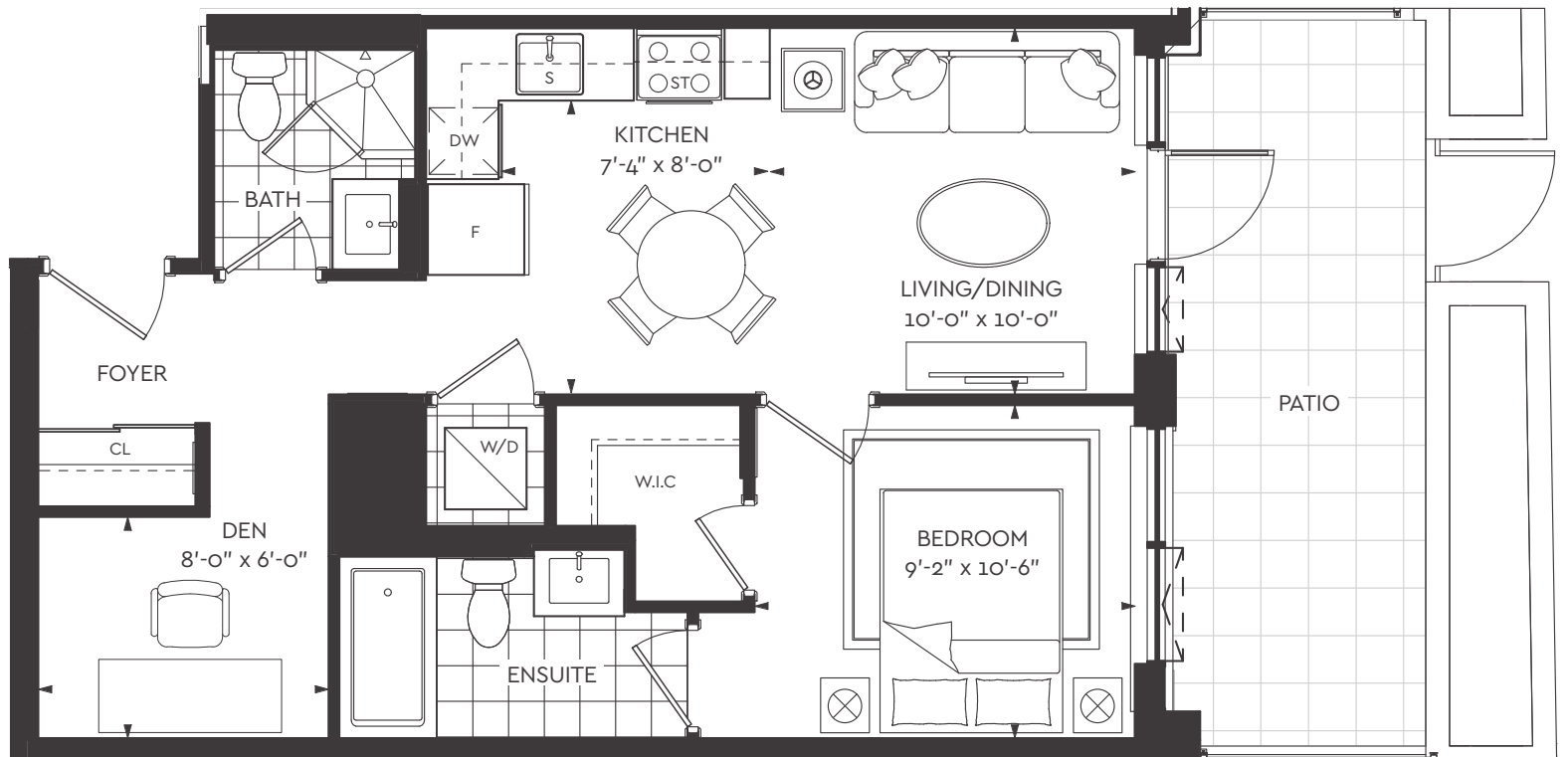

Level 1



1B+D

UNIT TYPE: 1 BEDROOM + DEN
 SUITE AREA: 661 sq.ft.
 OUTDOOR AREA: 87-131 sq.ft.
 TOTAL AREA: 748-792 sq.ft.

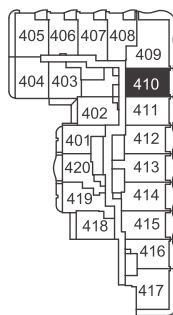
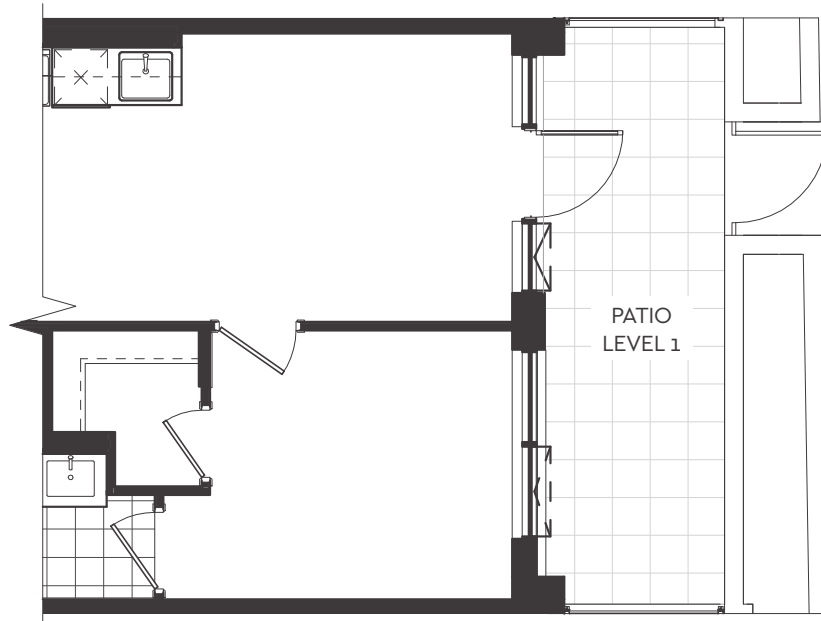
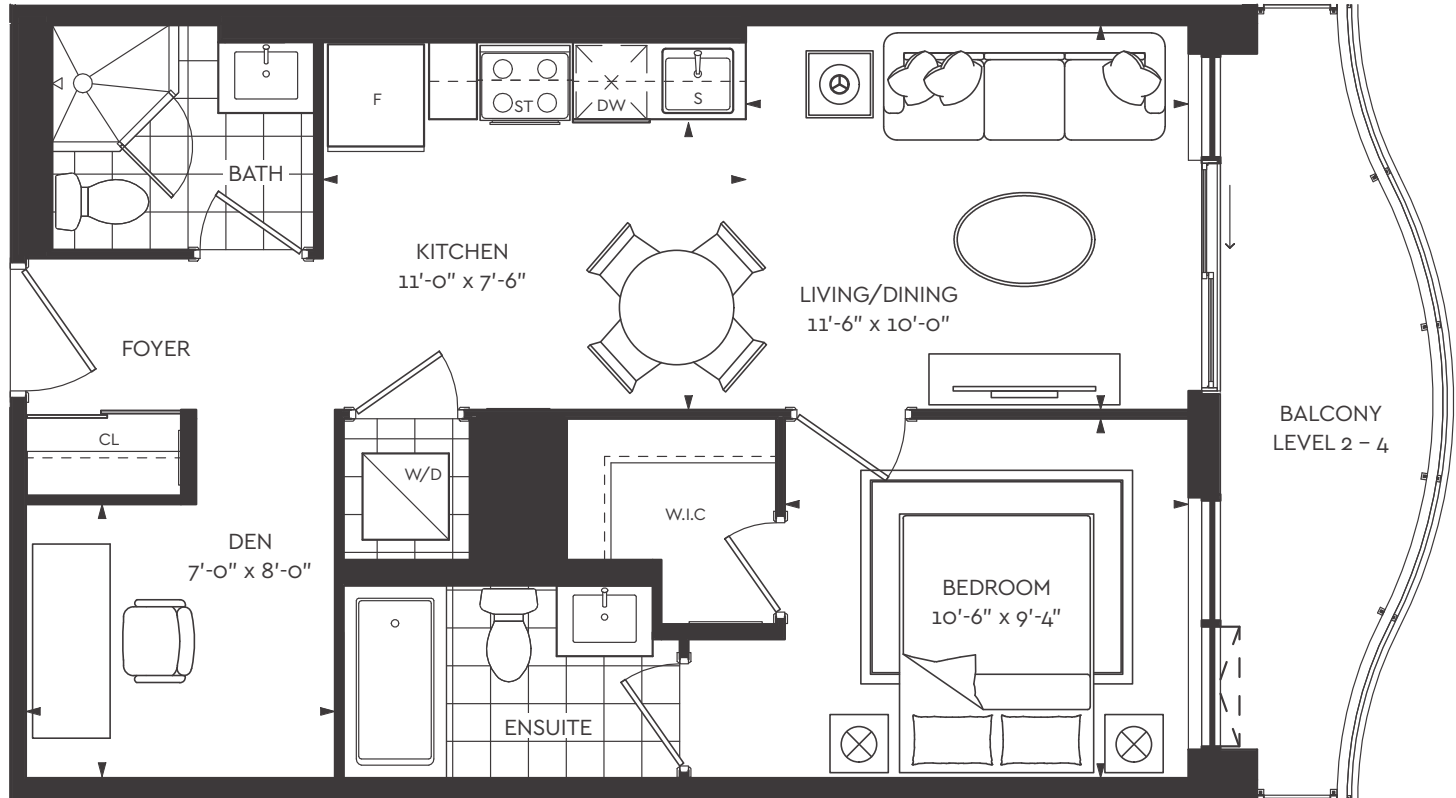

Level 4

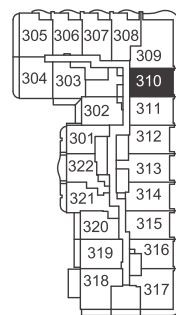

Level 3

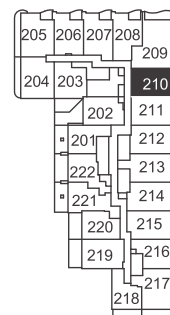

Level 2

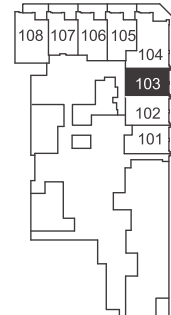

Level 1



1C+D

UNIT TYPE: 1 BEDROOM + DEN
 SUITE AREA: 650 sq.ft.
 OUTDOOR AREA: 163 sq.ft.
 TOTAL AREA: 813 sq.ft.

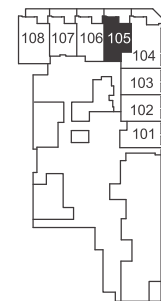
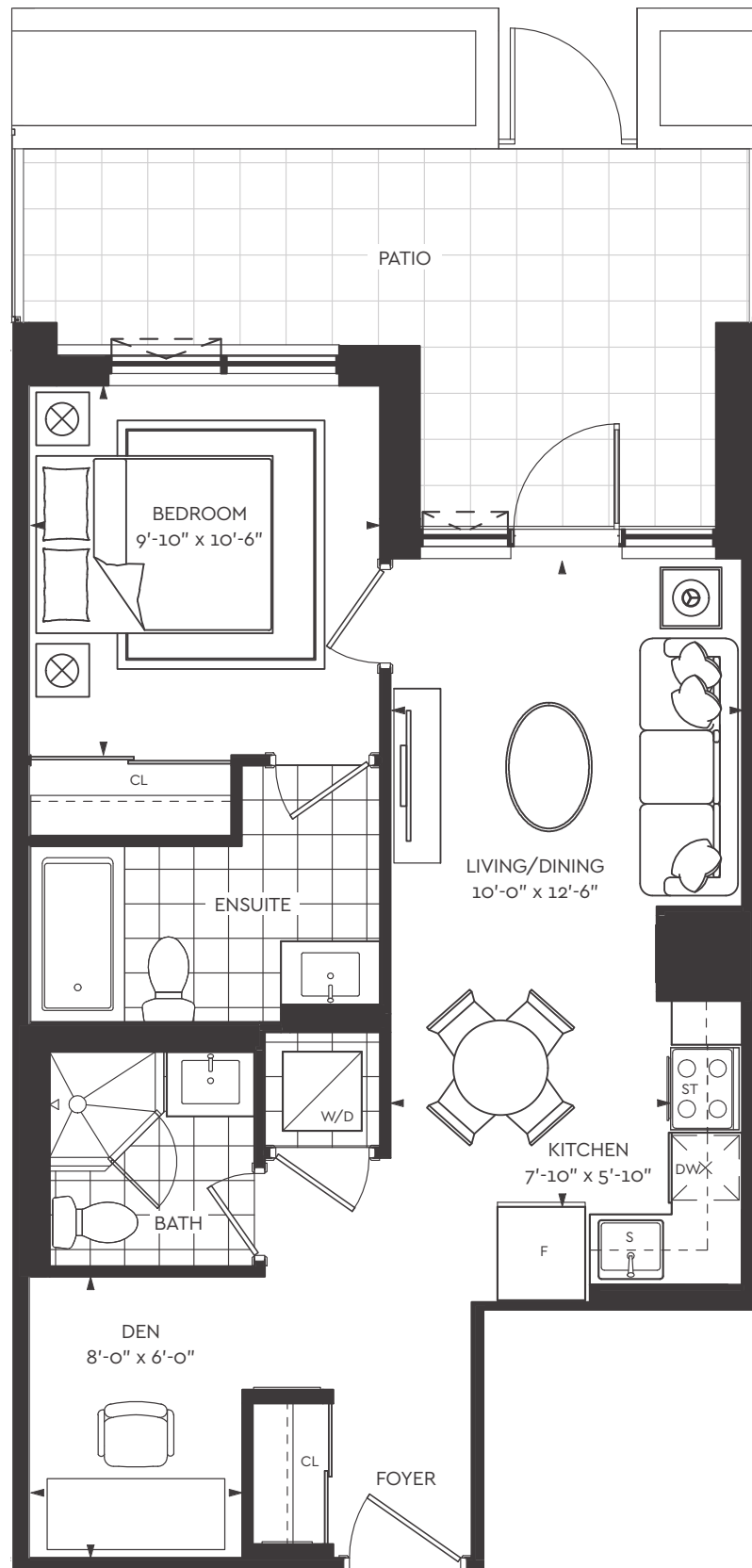

Level 1



1D+D

UNIT TYPE: 1 BEDROOM + DEN
 SUITE AREA: 681 sq.ft.
 OUTDOOR AREA: 163 sq.ft.
 TOTAL AREA: 844 sq.ft.

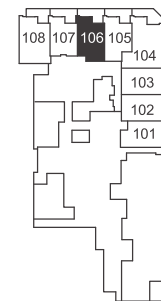
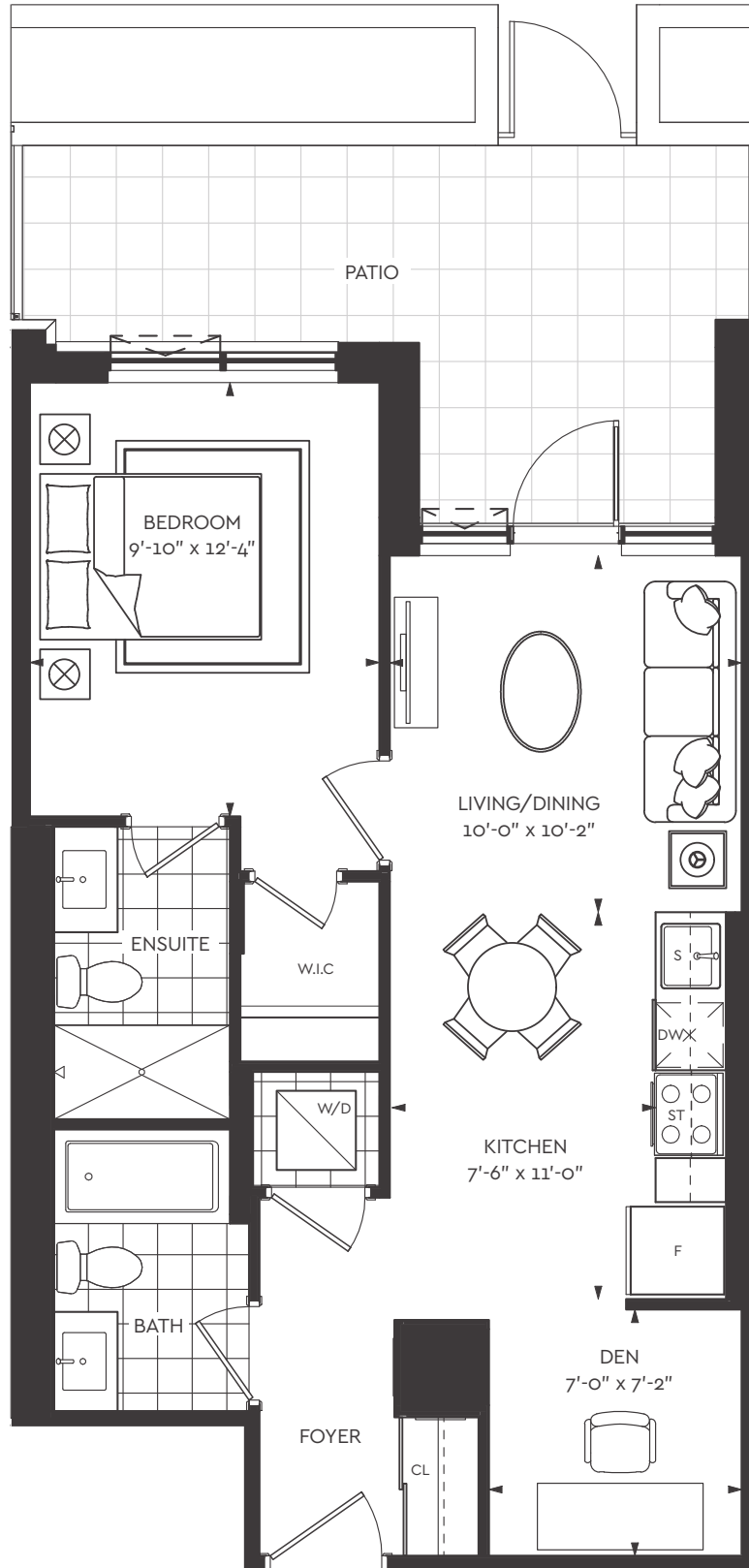

Level 1



1E+D

UNIT TYPE: 1 BEDROOM + DEN
 SUITE AREA: 615 sq.ft.
 OUTDOOR AREA: 57-163 sq.ft.
 TOTAL AREA: 672-778 sq.ft.

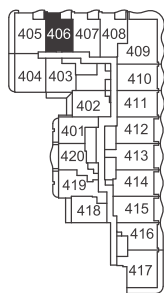
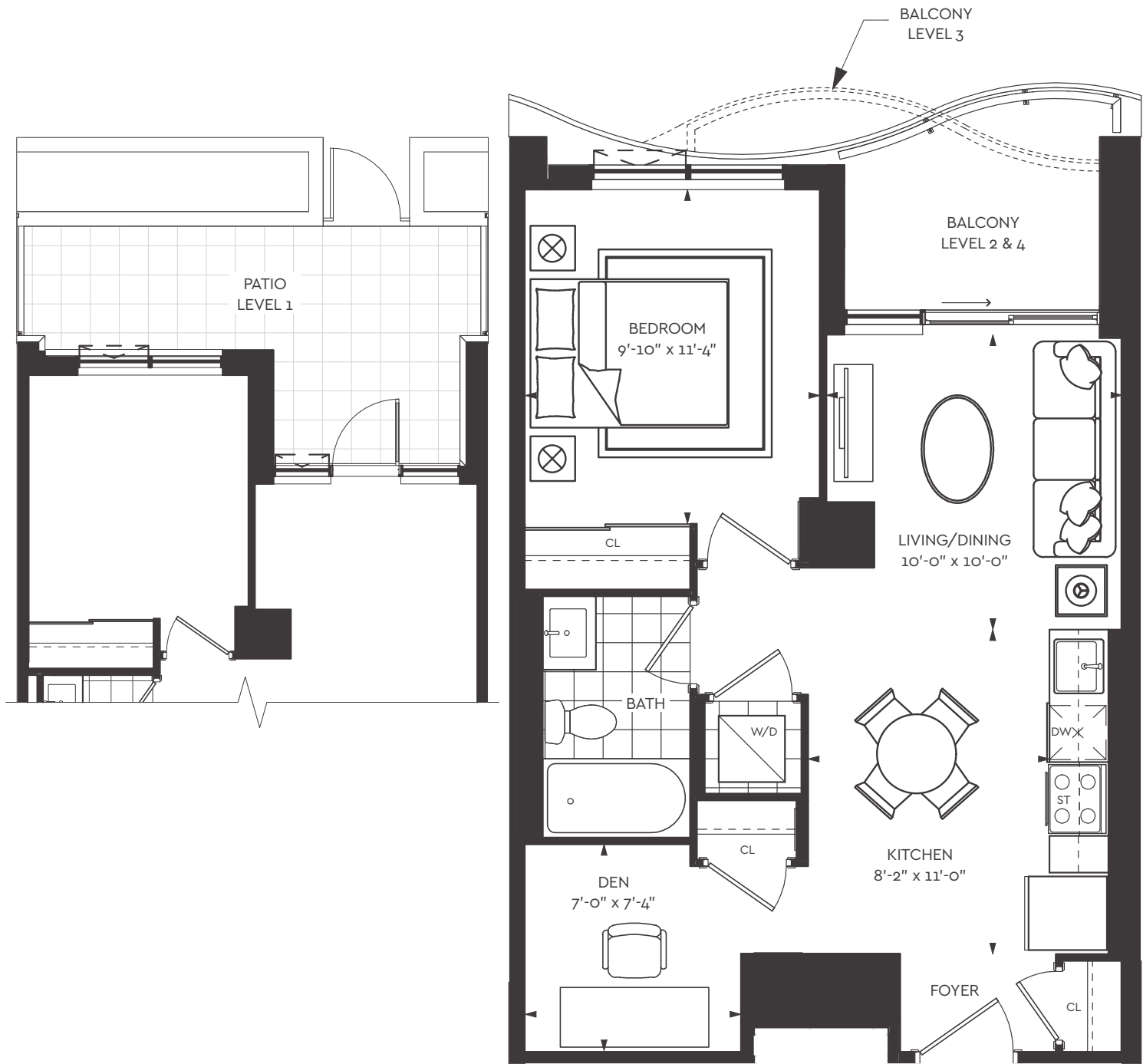

Level 4

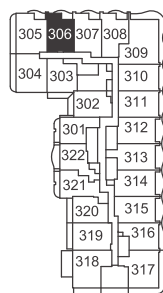

Level 3

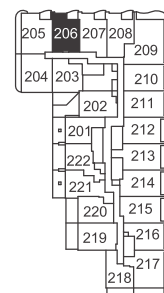

Level 2

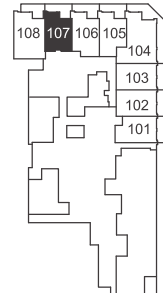

Level 1



1F+D

UNIT TYPE: 1 BEDROOM + DEN
 SUITE AREA: 686 sq.ft.
 OUTDOOR AREA: 115-126 sq.ft.
 TOTAL AREA: 801-812 sq.ft.

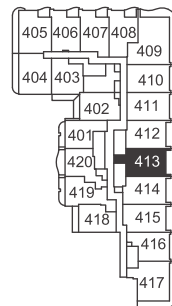
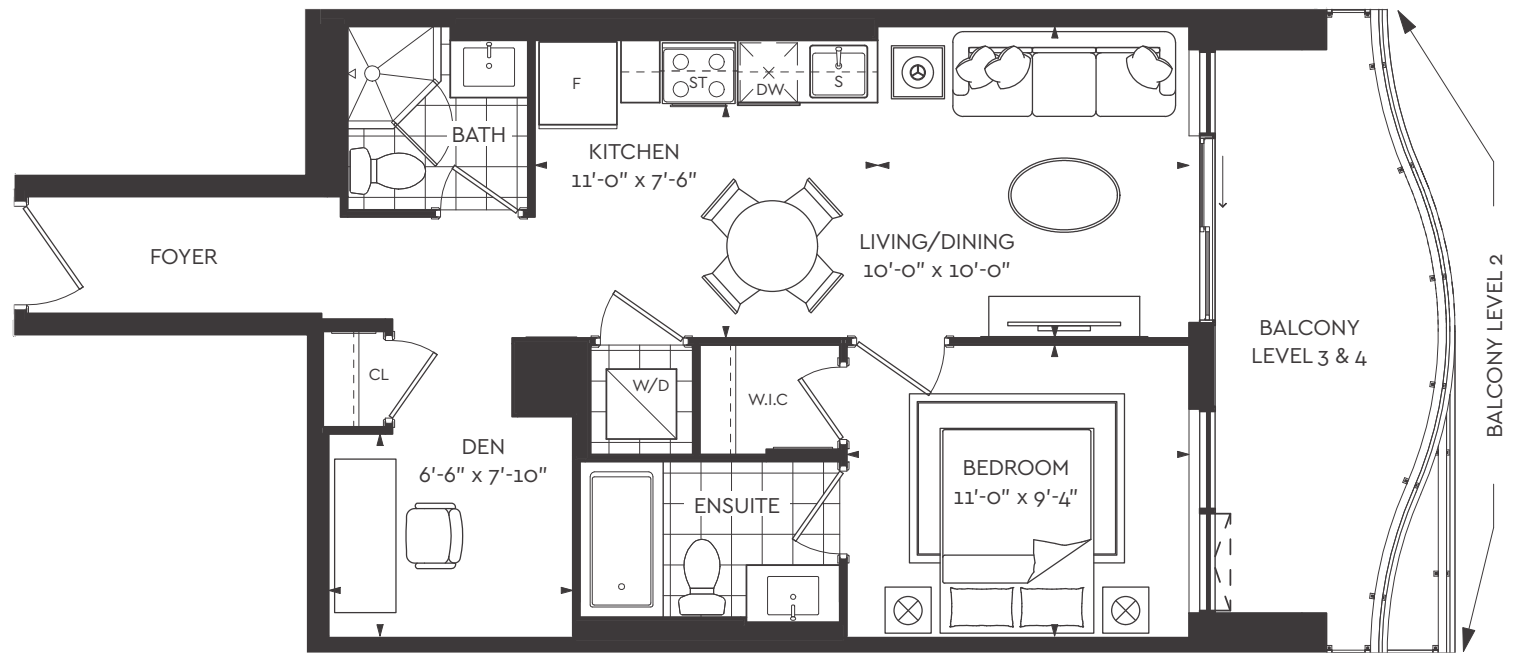

Level 4

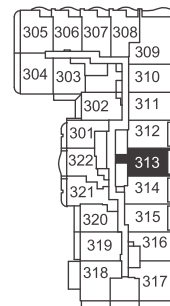

Level 3

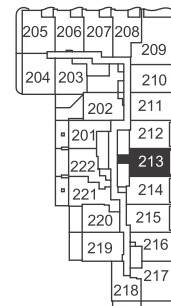

Level 2



1G+D

UNIT TYPE: 1 BEDROOM + DEN
 SUITE AREA: 661 sq.ft.
 OUTDOOR AREA: 115-138 sq.ft.
 TOTAL AREA: 776-799 sq.ft.

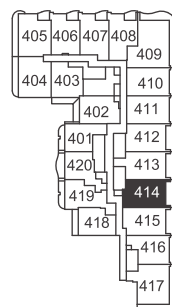
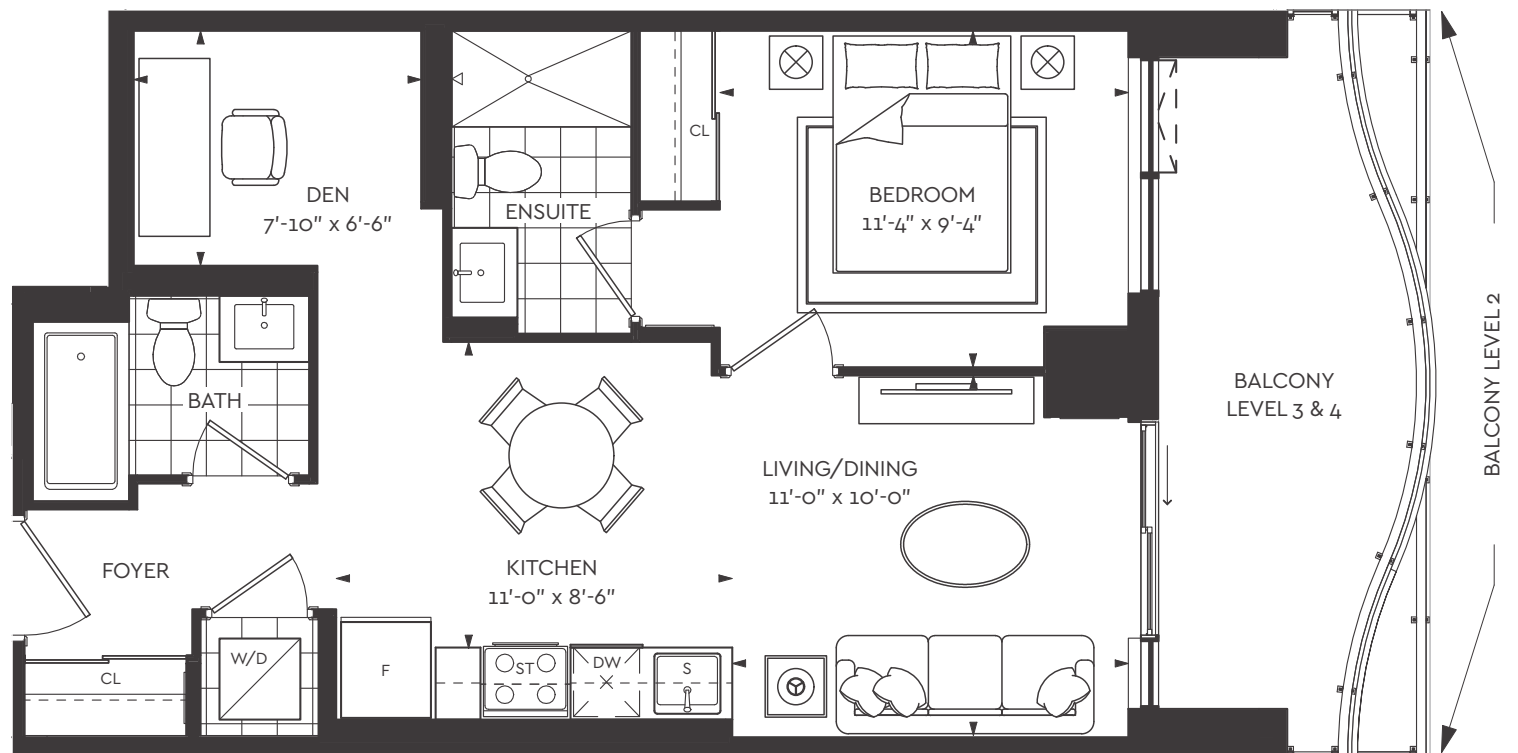

Level 4

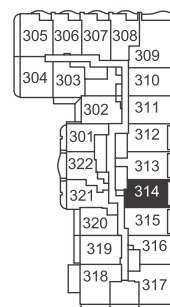

Level 3

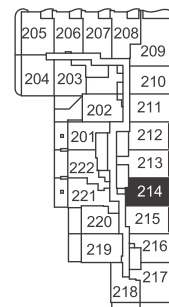

Level 2



1H+D

UNIT TYPE: 1 BEDROOM + DEN
 SUITE AREA: 662 sq.ft.
 OUTDOOR AREA: 115-138 sq.ft.
 TOTAL AREA: 777-800 sq.ft.

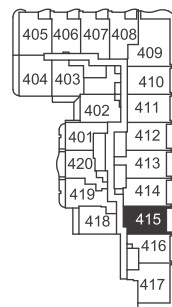
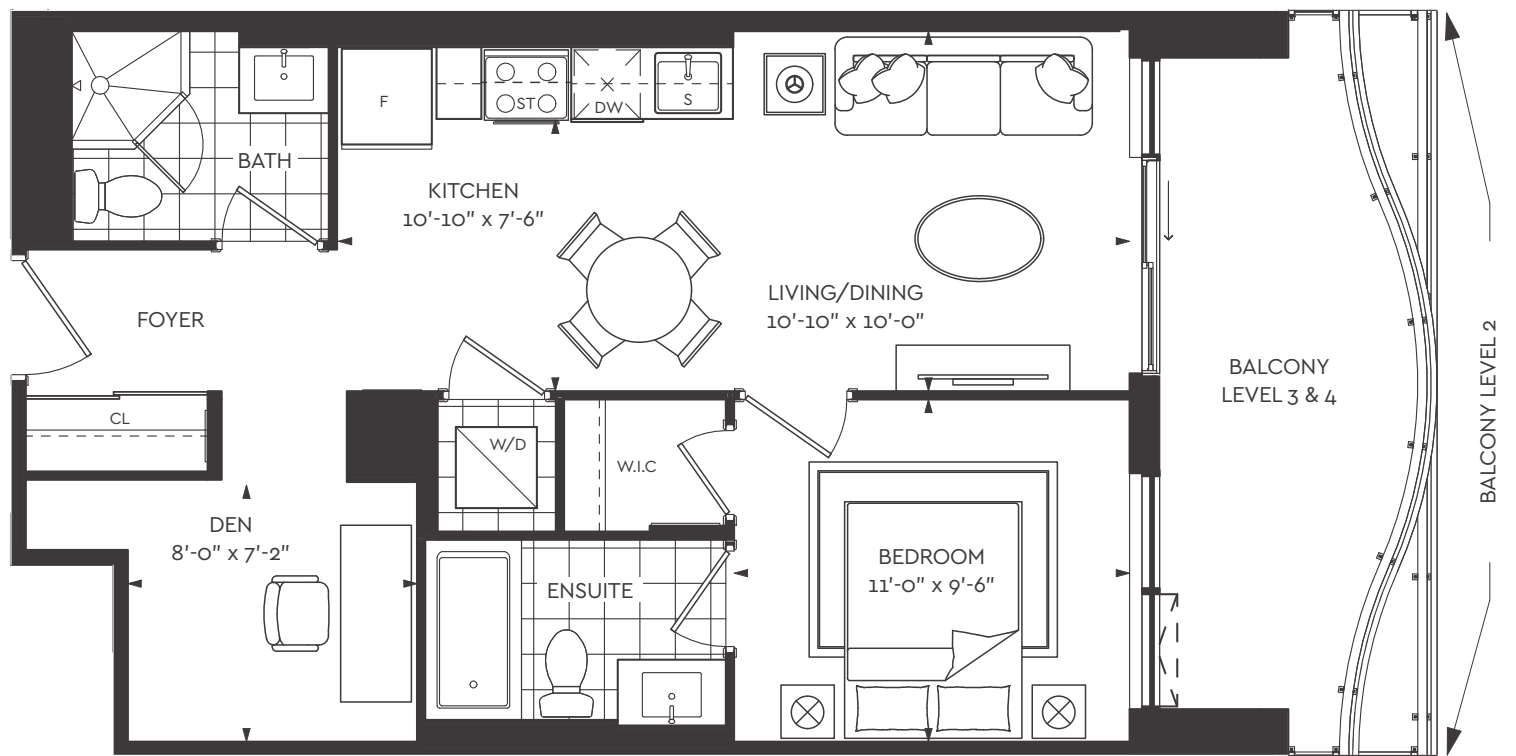

Level 4

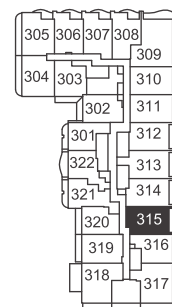

Level 3

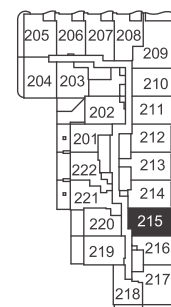

Level 2



1J+D

UNIT TYPE: 1 BEDROOM + DEN
 SUITE AREA: 579 sq.ft.
 OUTDOOR AREA: 83-94 sq.ft.
 TOTAL AREA: 662-673 sq.ft.

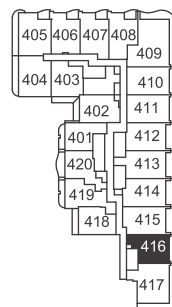
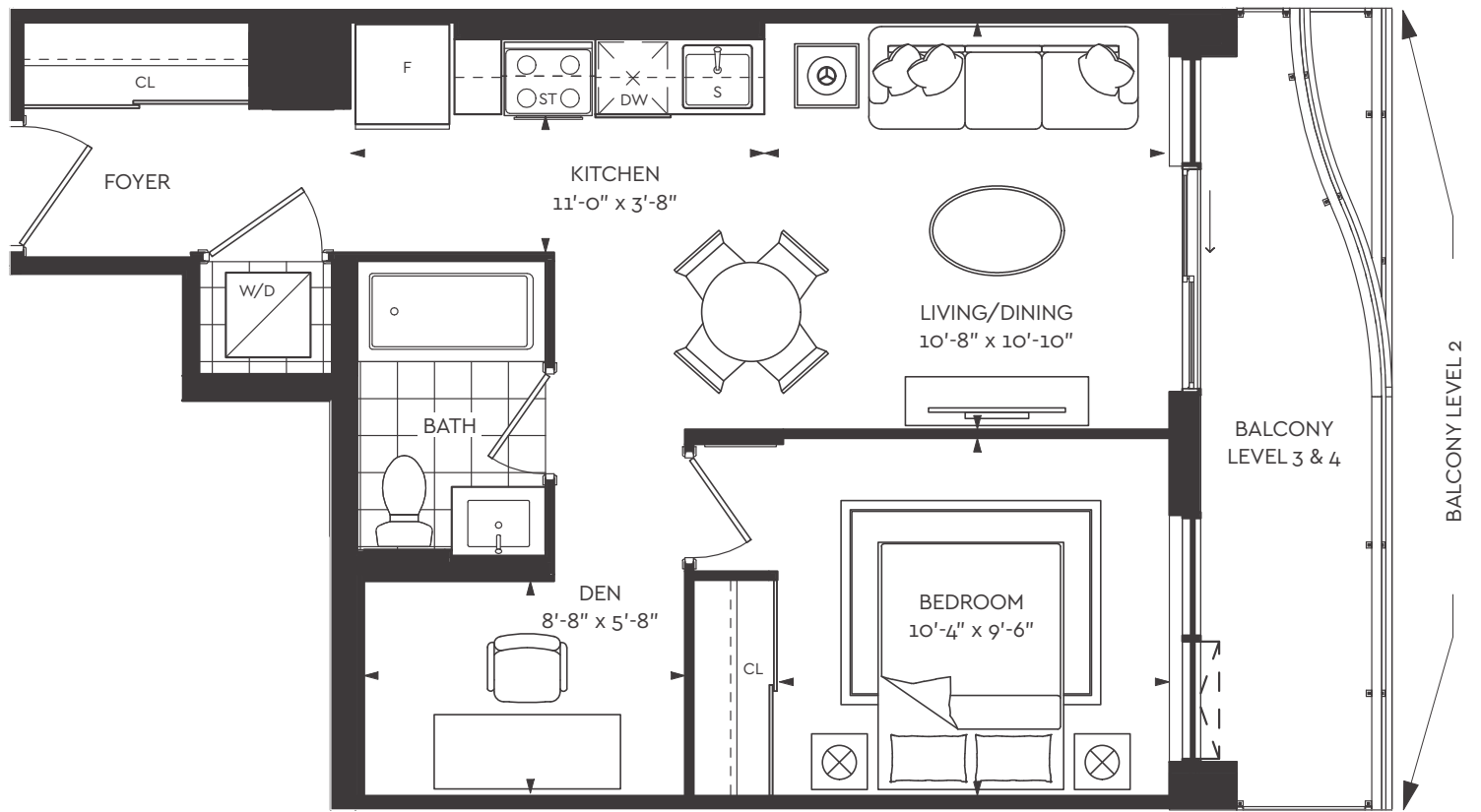

Level 4

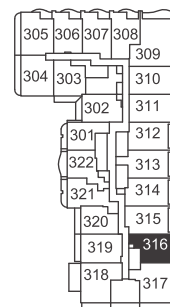

Level 3

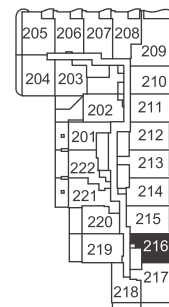

Level 2



1K+D

UNIT TYPE: 1 BEDROOM + DEN
 SUITE AREA: 655 sq.ft.
 OUTDOOR AREA: 92-195 sq.ft.
 TOTAL AREA: 747-850 sq.ft.

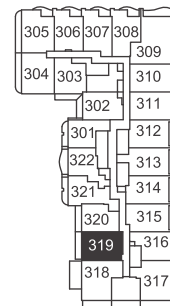
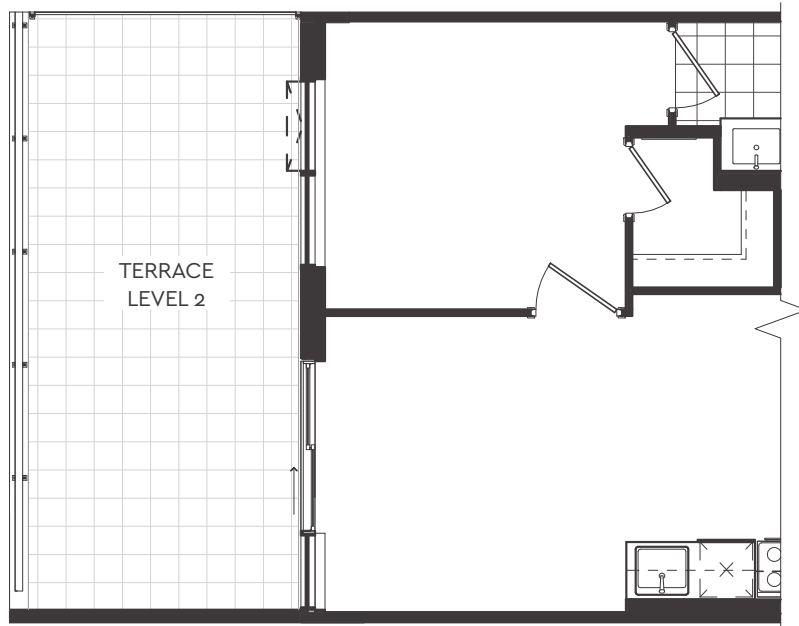
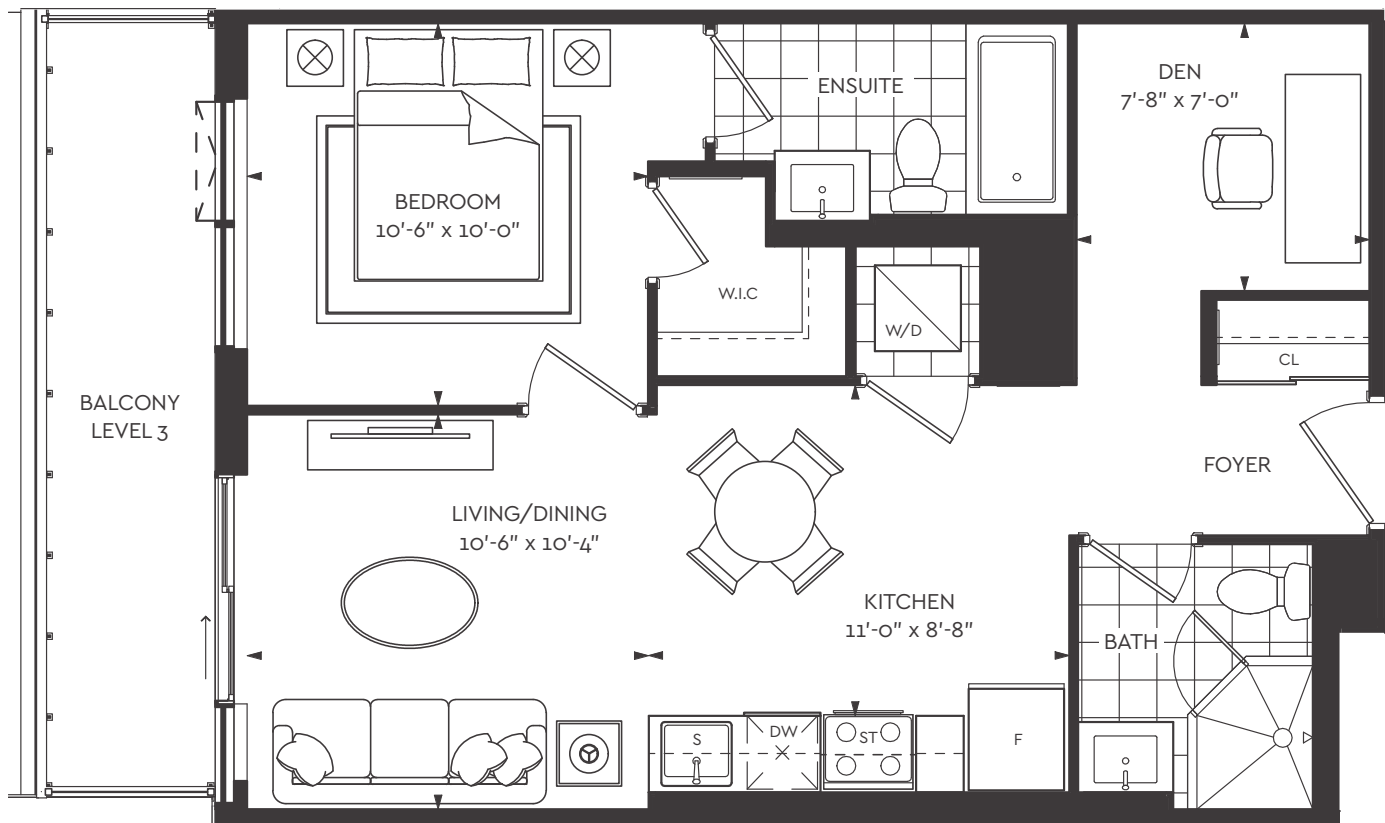

Level 3

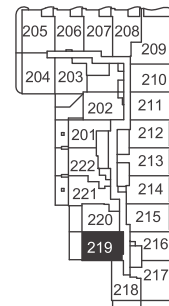

Level 2



1L+D

UNIT TYPE: 1 BEDROOM + DEN
 SUITE AREA: 535 sq.ft.
 OUTDOOR AREA: 88-183 sq.ft.
 TOTAL AREA: 623-718 sq.ft.

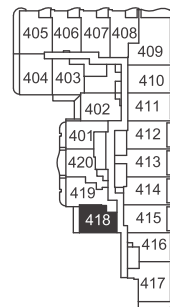
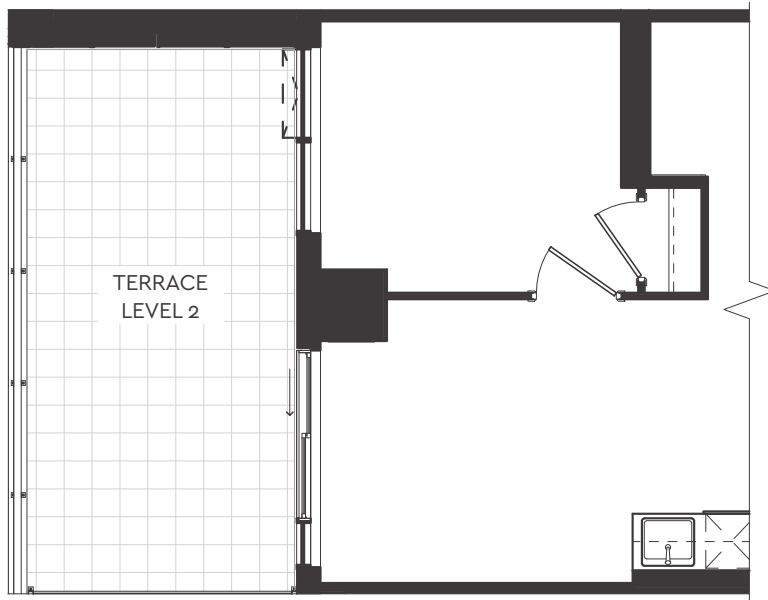

Level 4

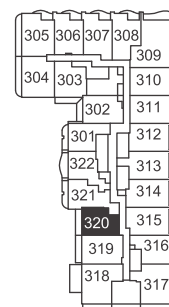

Level 3

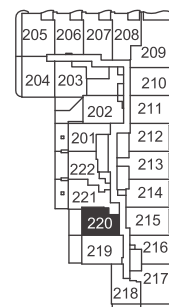

Level 2



1M+D

UNIT TYPE: 1 BEDROOM + DEN
 SUITE AREA: 621 sq.ft.
 OUTDOOR AREA: 87-203 sq.ft.
 TOTAL AREA: 708-824 sq.ft.

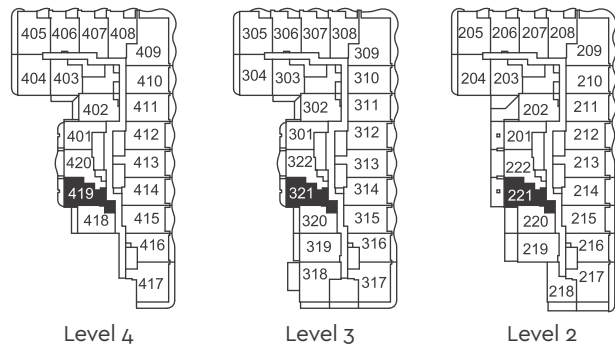
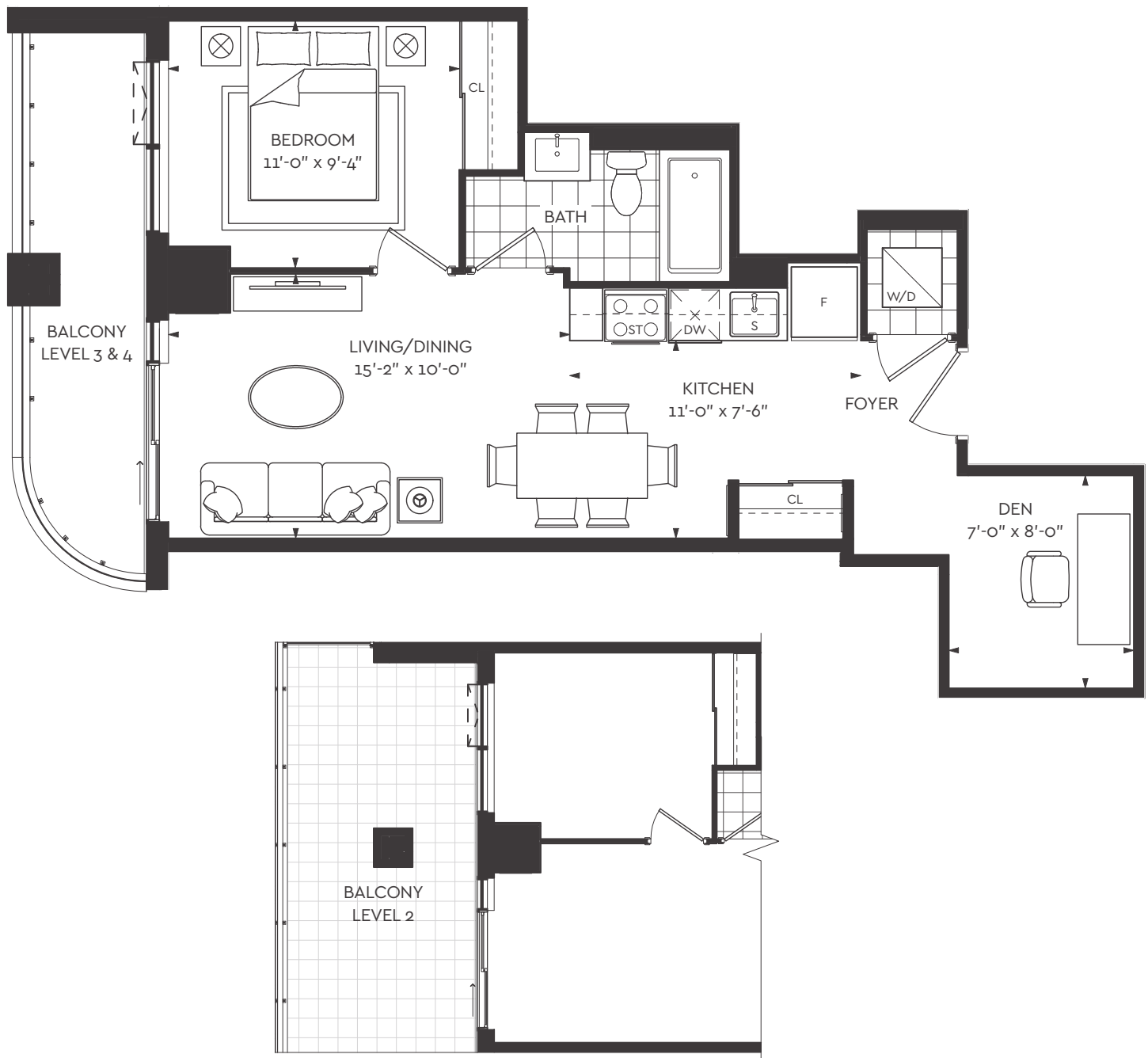

1N+D

UNIT TYPE: 1 BEDROOM + DEN
 SUITE AREA: 601 sq.ft.
 OUTDOOR AREA: 71-229 sq.ft.
 TOTAL AREA: 672-830 sq.ft.

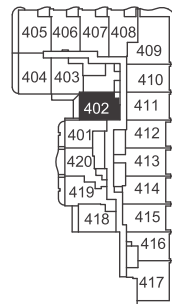
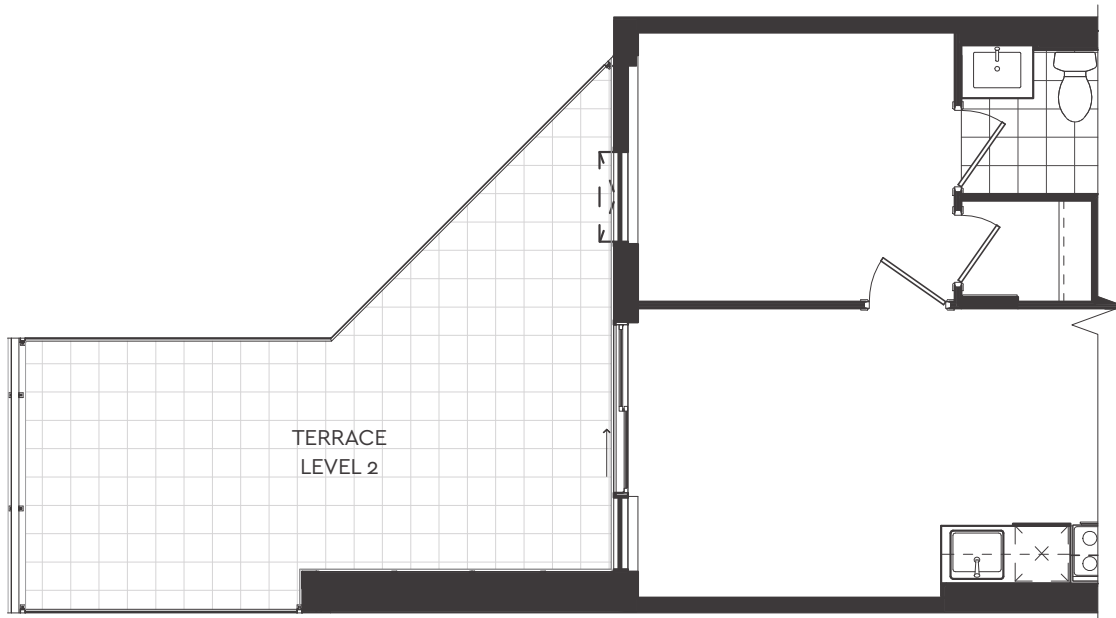
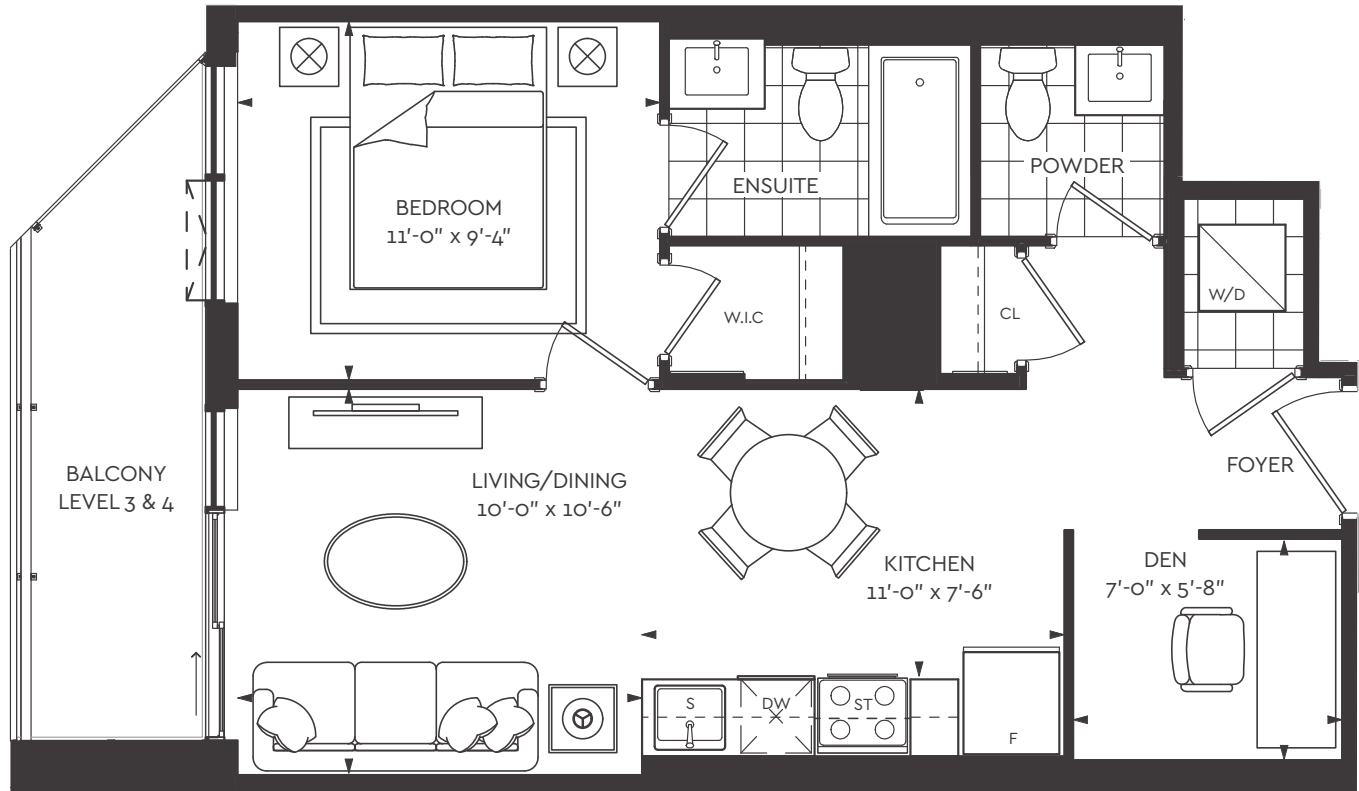

Level 4

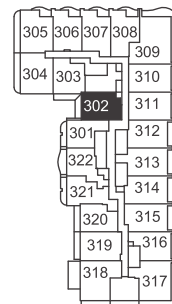

Level 3

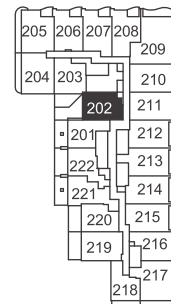

Level 2



1P+D

UNIT TYPE: 1 BEDROOM + DEN
 SUITE AREA: 585 sq.ft.
 OUTDOOR AREA: 83-155 sq.ft.
 TOTAL AREA: 668-740 sq.ft.

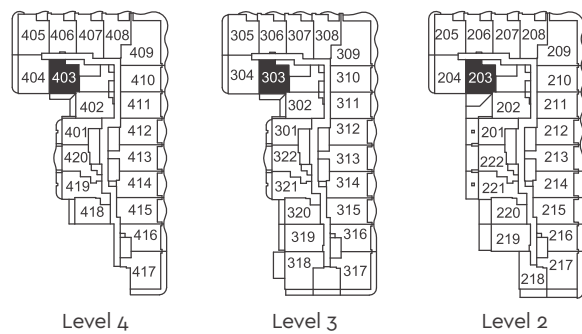
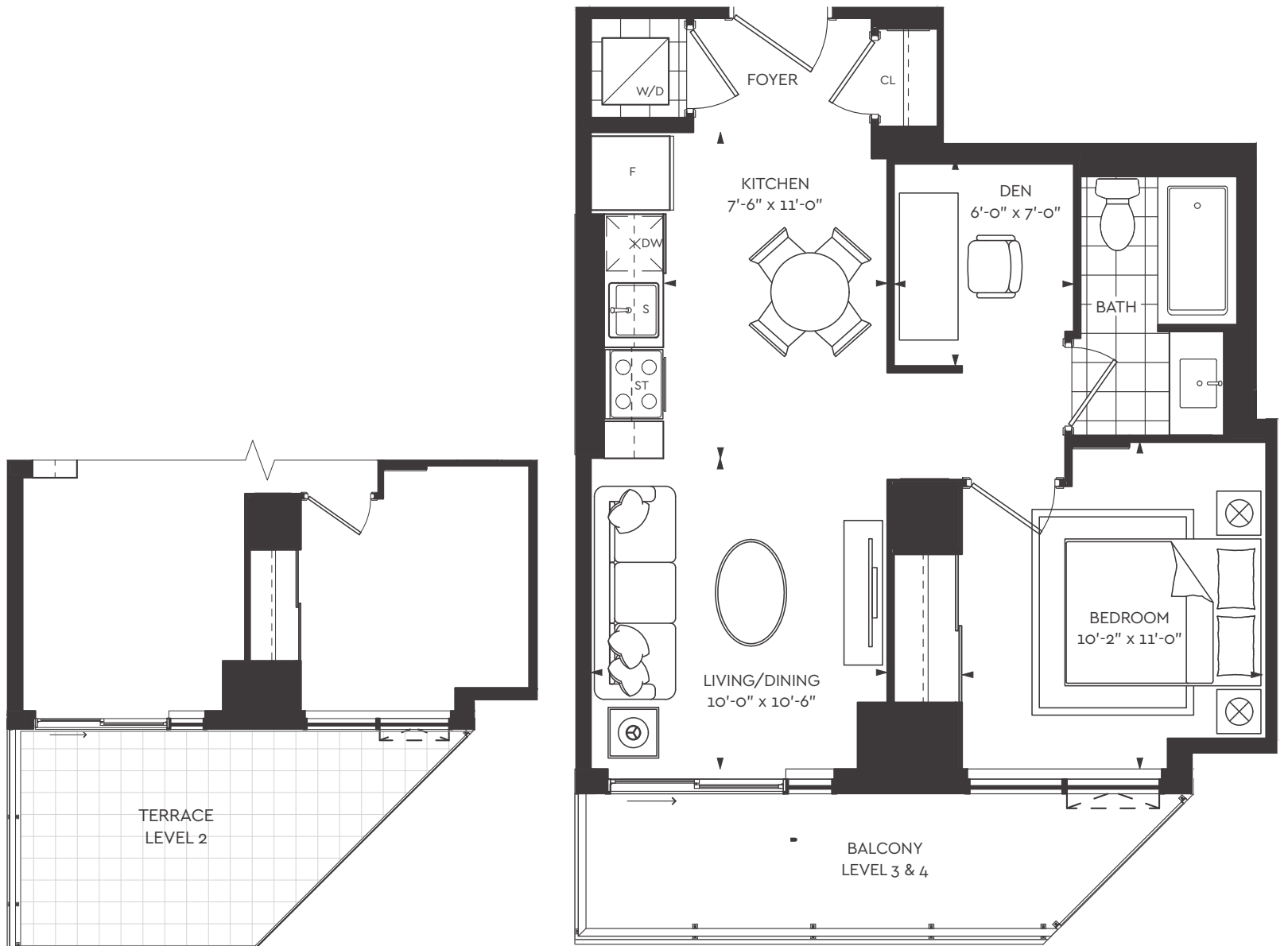

1Q+D

UNIT TYPE: 1 BEDROOM + DEN
 SUITE AREA: 651 sq.ft.
 OUTDOOR AREA: 57-61 sq.ft.
 TOTAL AREA: 708-712 sq.ft.

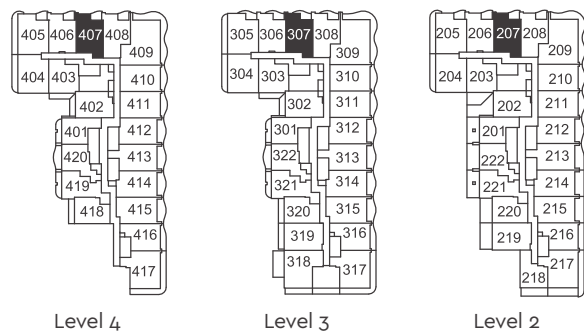
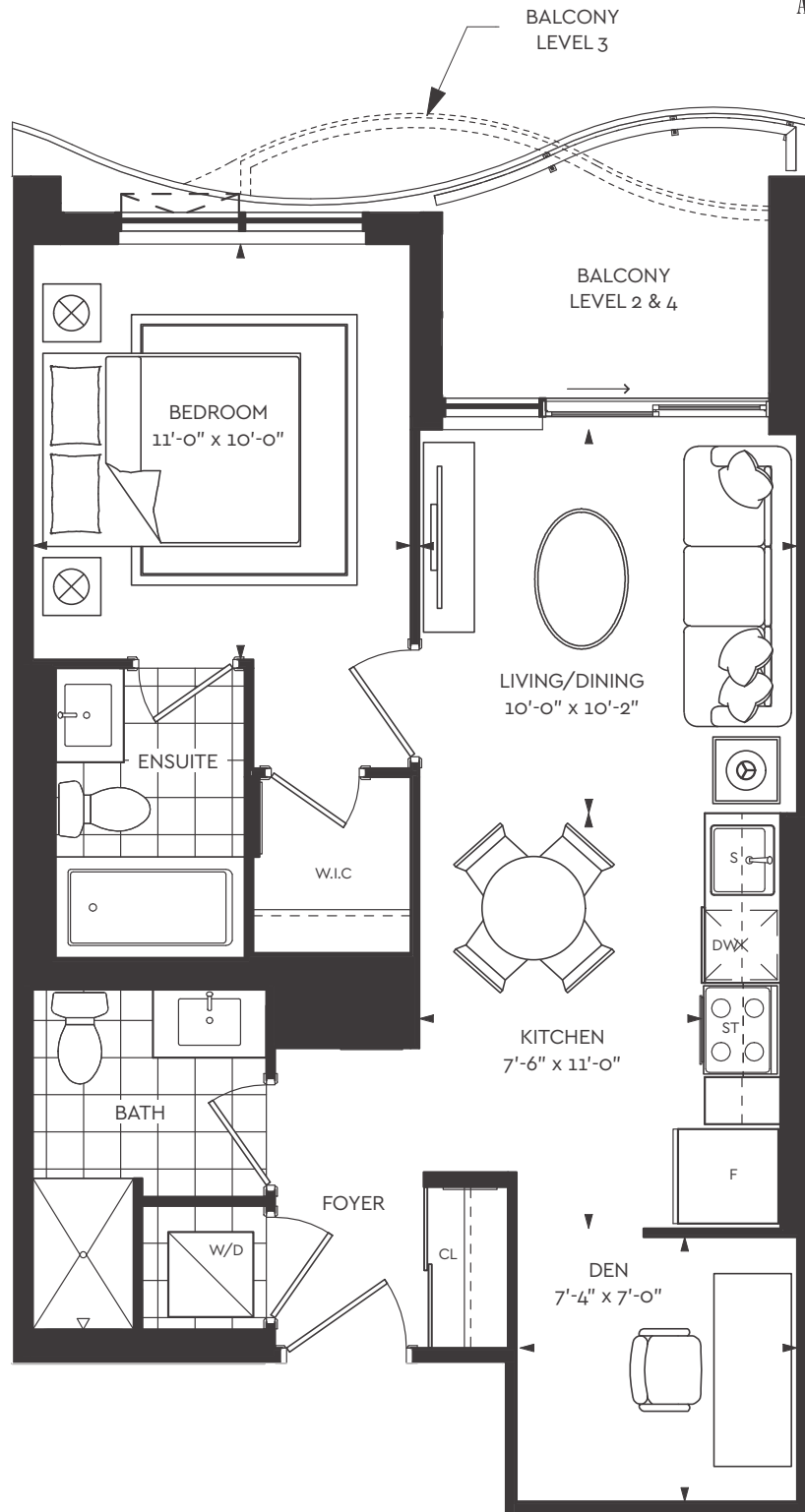

Without limiting the generality of the terms and conditions of the agreement of purchase and sale, Purchasers are advised that all prices, figures, sizes, plans, specifications and information, including without limitation the size, location, design and layout of windows, doors, walls, fixtures, closets, structures, appliances (if any), and the balcony are subject to change without notice to the Purchaser in order to comply with site conditions, municipal or governmental, structural, or architectural requirements, or for any reason at the sole, unfettered and absolute discretion of the Vendor. Units on lower floors may have less floor space due to thicker structural members, mechanical rooms, etc. while units on higher floors may have more floorspace. Bulkheads may not be shown on this plan and may be located in areas of the Unit as required for venting and mechanical systems. All areas and stated dimensions are approximate. Actual usable floor space, living area and square footage may vary from stated floor area. All illustrations are artist's concept only. Furniture is depicted for illustration purposes only & are not included. The unit shown may be the reverse of the unit purchased. The exact location of any balcony (if applicable) in relation to the unit layout may differ from that shown. The locations of the building and units shown are approximate only and are subject to change without notice to the Purchaser. E. & O.E. OCTOBER 2022.

1R+D

UNIT TYPE: 1 BEDROOM + DEN
 SUITE AREA: 629 sq.ft.
 OUTDOOR AREA: 57-61 sq.ft.
 TOTAL AREA: 686- 690 sq.ft.

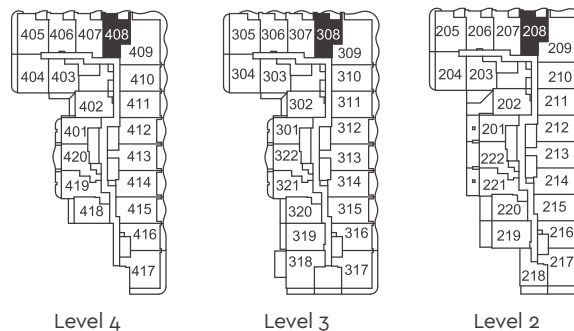
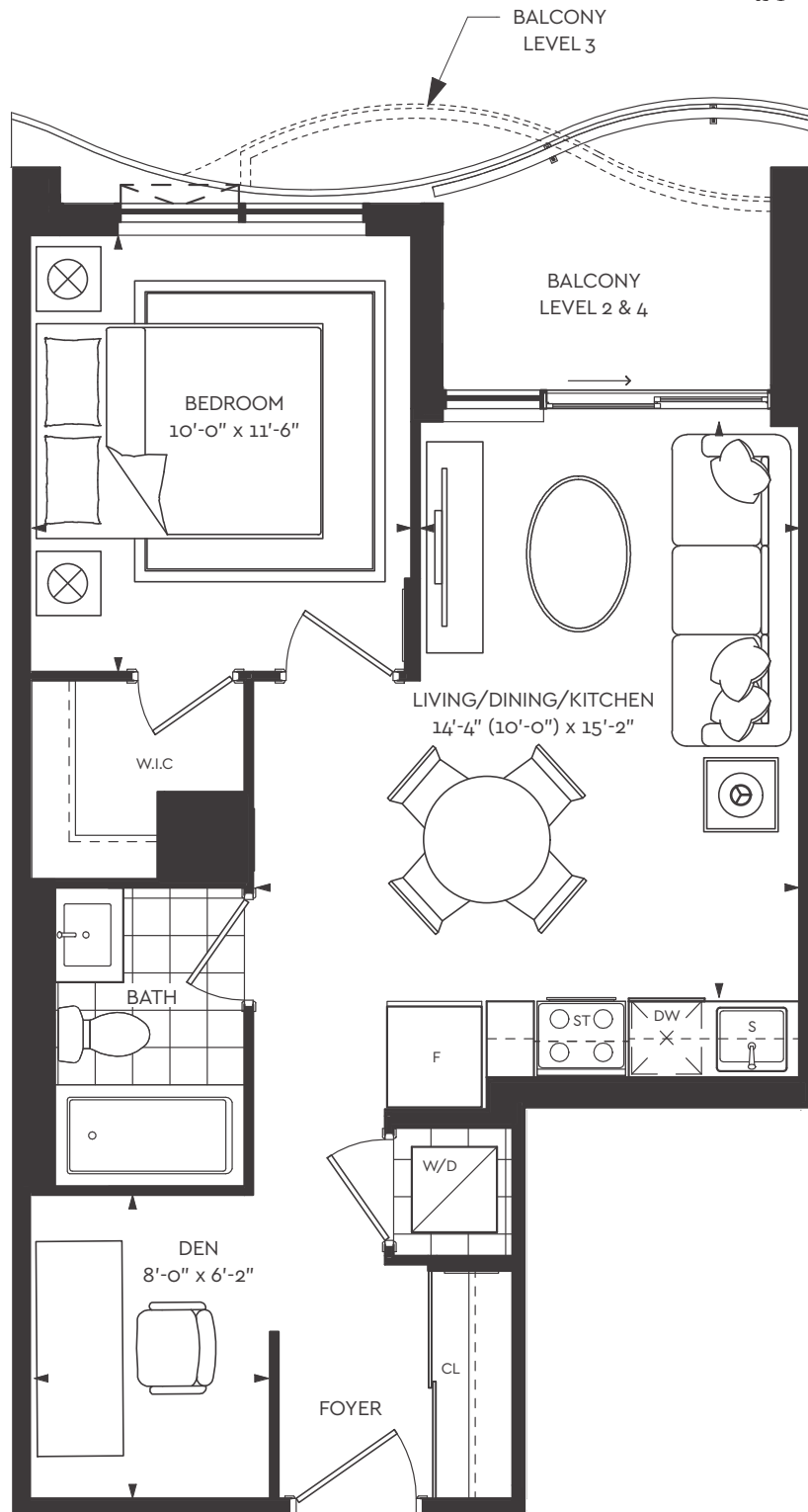

1S+D

UNIT TYPE: 1 BEDROOM + DEN
 SUITE AREA: 625 sq.ft.
 OUTDOOR AREA: 115 sq.ft.
 TOTAL AREA: 740 sq.ft.

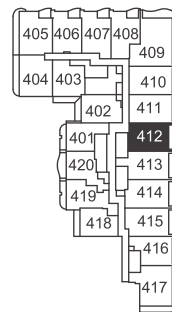
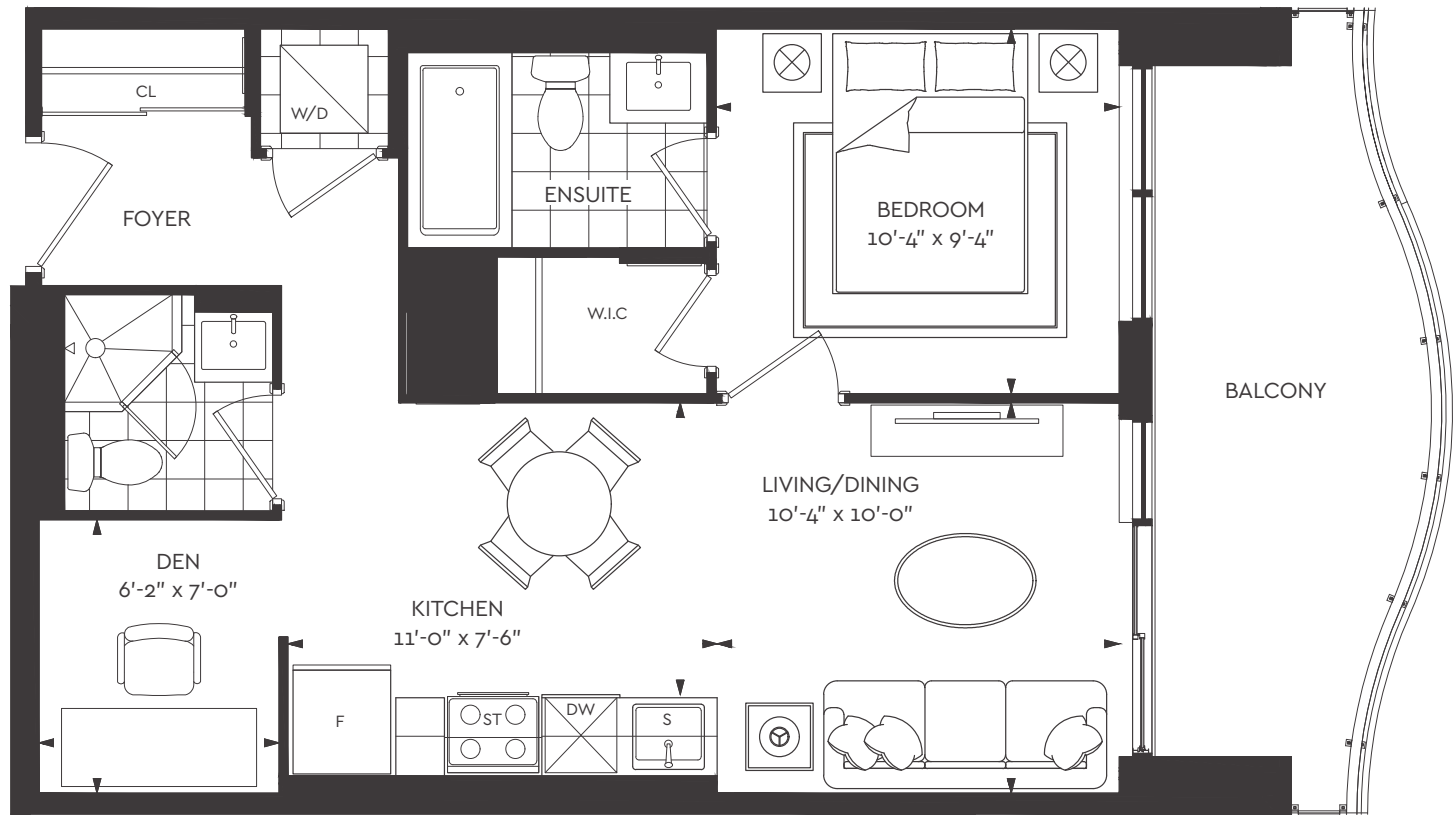

Level 4

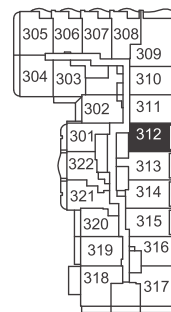

Level 3

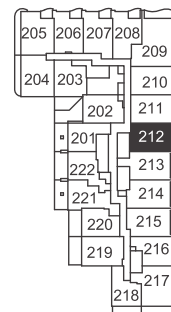

Level 2



1T+D

UNIT TYPE: 1 BEDROOM + DEN
 SUITE AREA: 623 sq.ft.
 OUTDOOR AREA: 101 sq.ft.
 TOTAL AREA: 724 sq.ft.

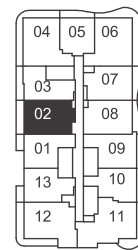
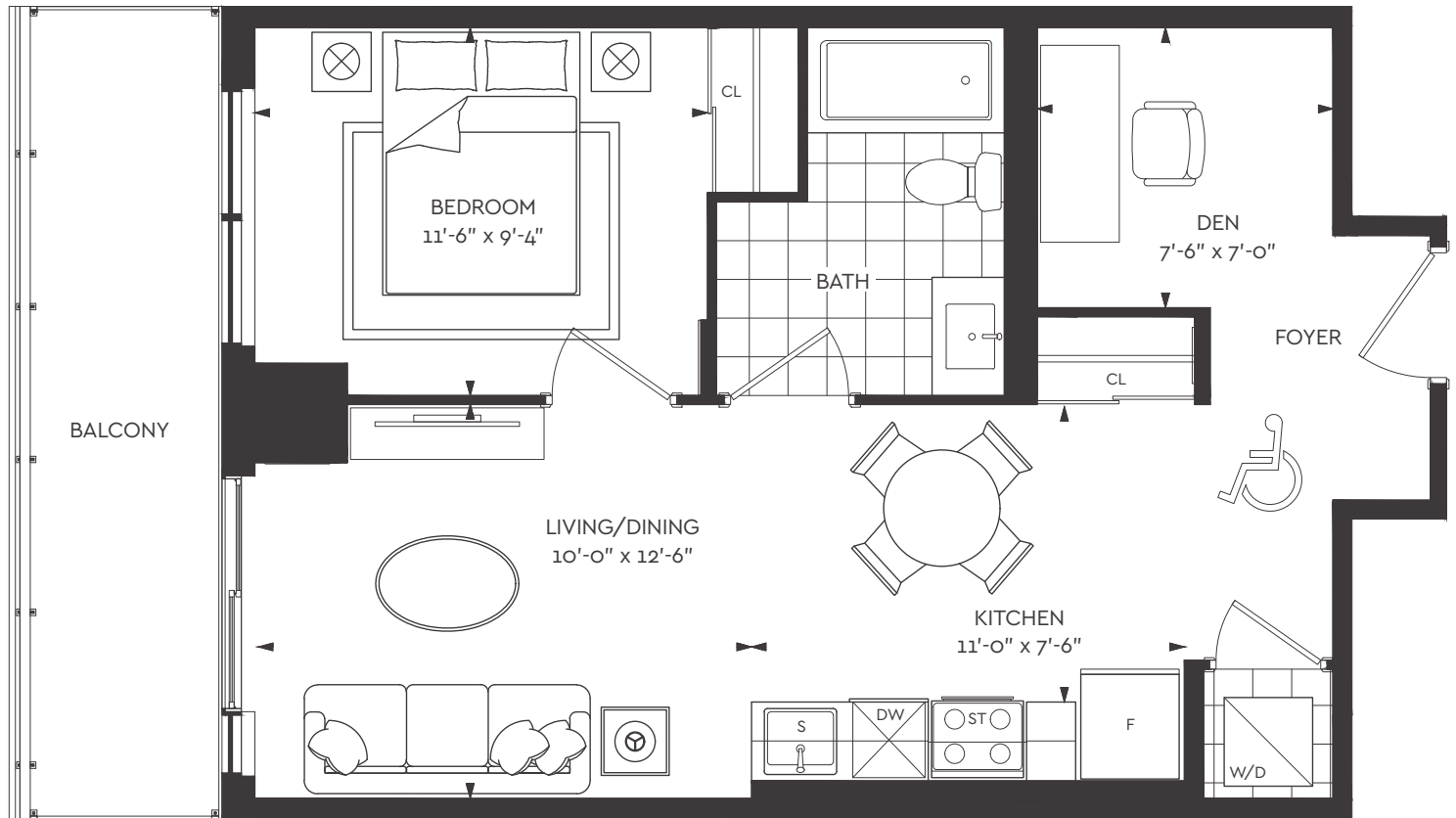

Level 7-18

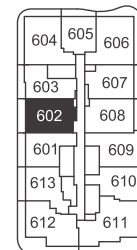

Level 6



1U+D

UNIT TYPE: 1 BEDROOM + DEN
 SUITE AREA: 576 sq.ft.
 OUTDOOR AREA: 89 sq.ft.
 TOTAL AREA: 665 sq.ft.

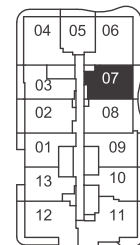
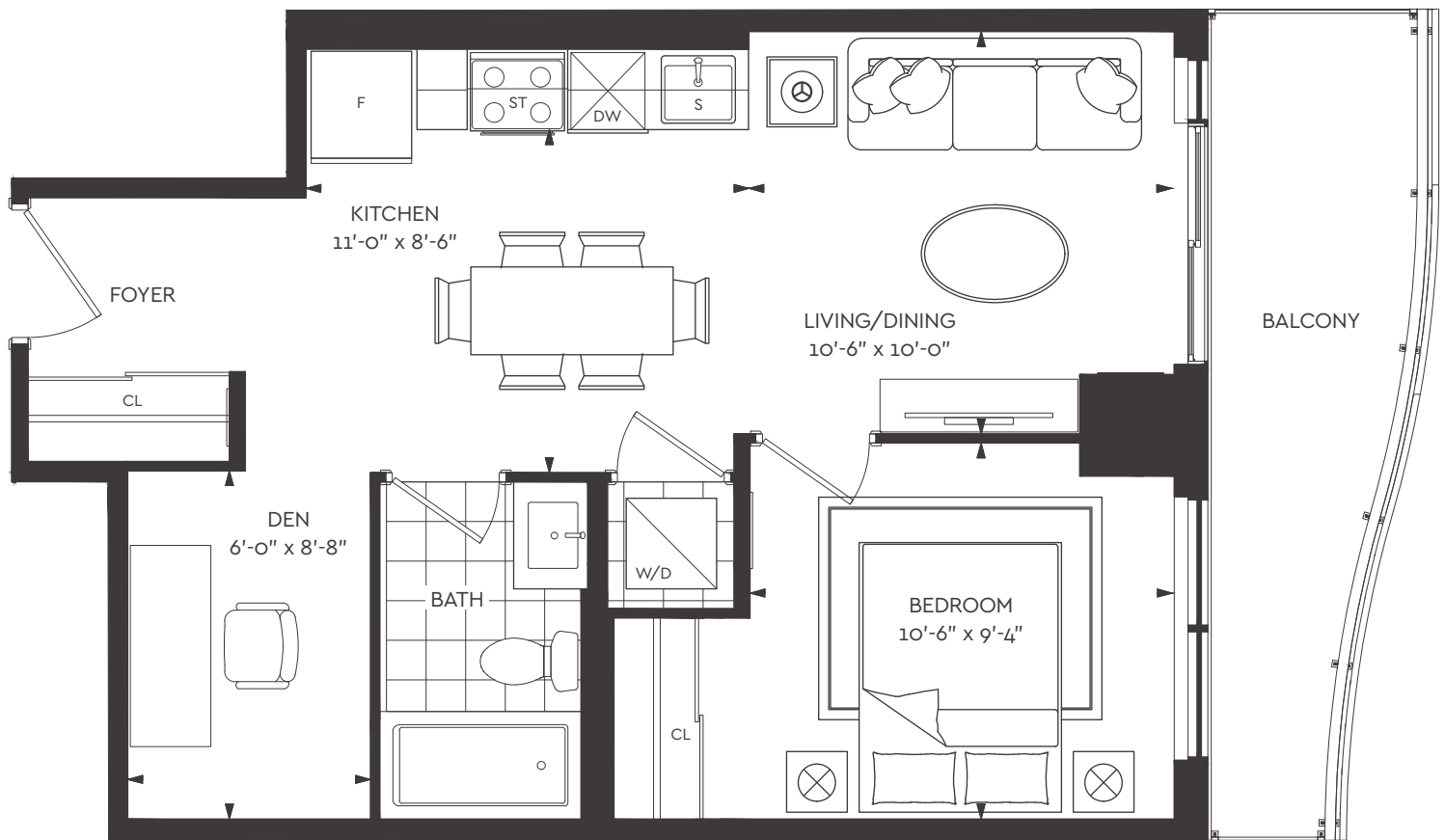

Level 7-35

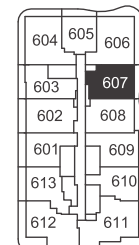

Level 6



1V+D

UNIT TYPE: 1 BEDROOM + DEN
 SUITE AREA: 608 sq.ft.
 OUTDOOR AREA: 97 sq.ft.
 TOTAL AREA: 705 sq.ft.

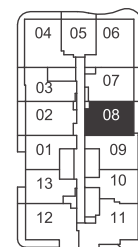
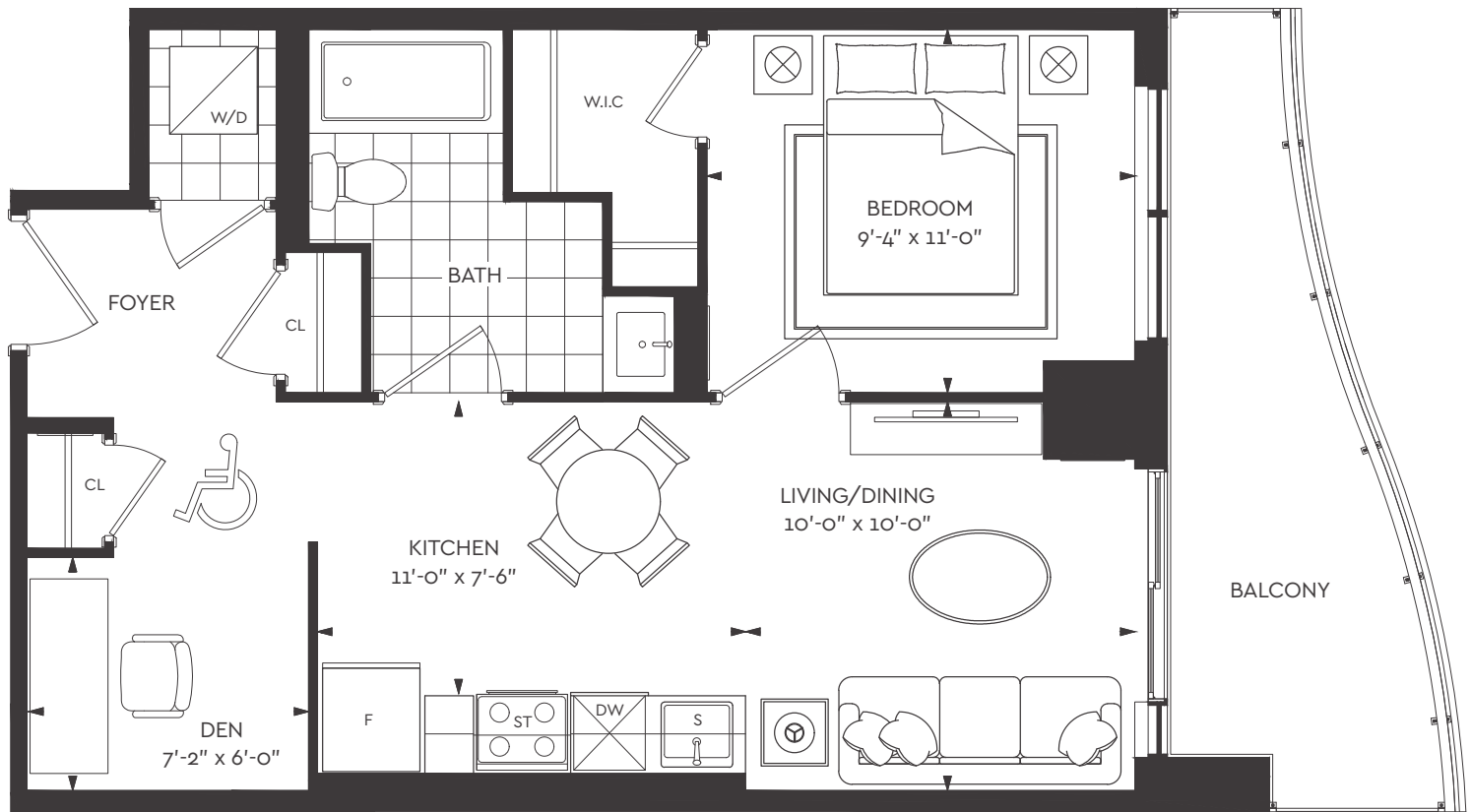

Level 7-35

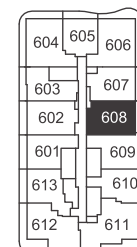

Level 6



1W+D

UNIT TYPE: 1 BEDROOM + DEN
 SUITE AREA: 567 sq.ft.
 OUTDOOR AREA: 94 sq.ft.
 TOTAL AREA: 661 sq.ft.

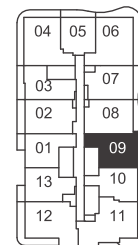
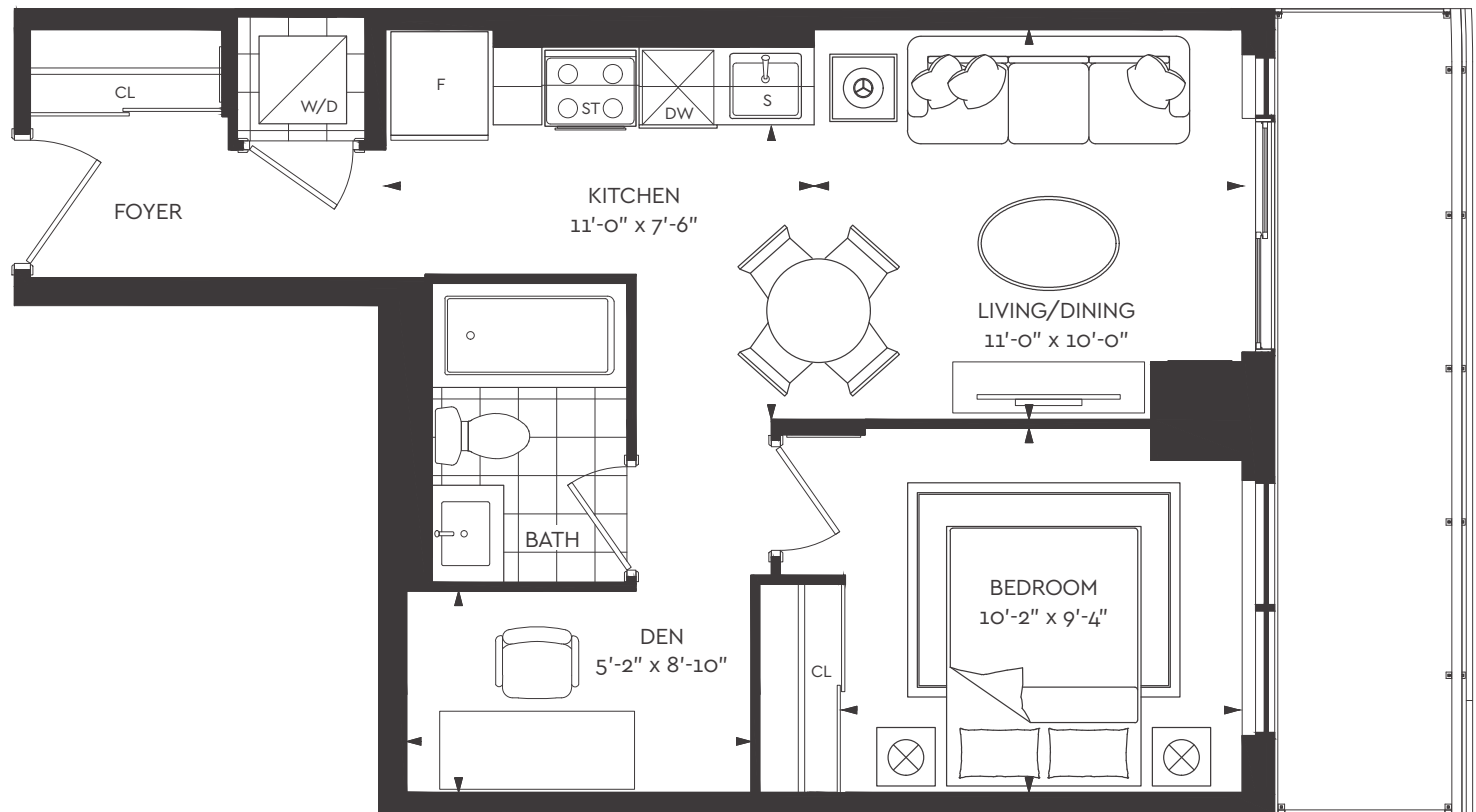

Level 7-35

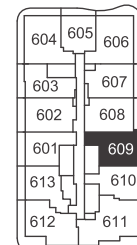

Level 6



1X+D

UNIT TYPE: 1 BEDROOM + DEN
 SUITE AREA: 623 sq.ft.
 OUTDOOR AREA: 101 sq.ft.
 TOTAL AREA: 724 sq.ft.

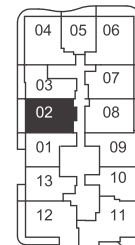
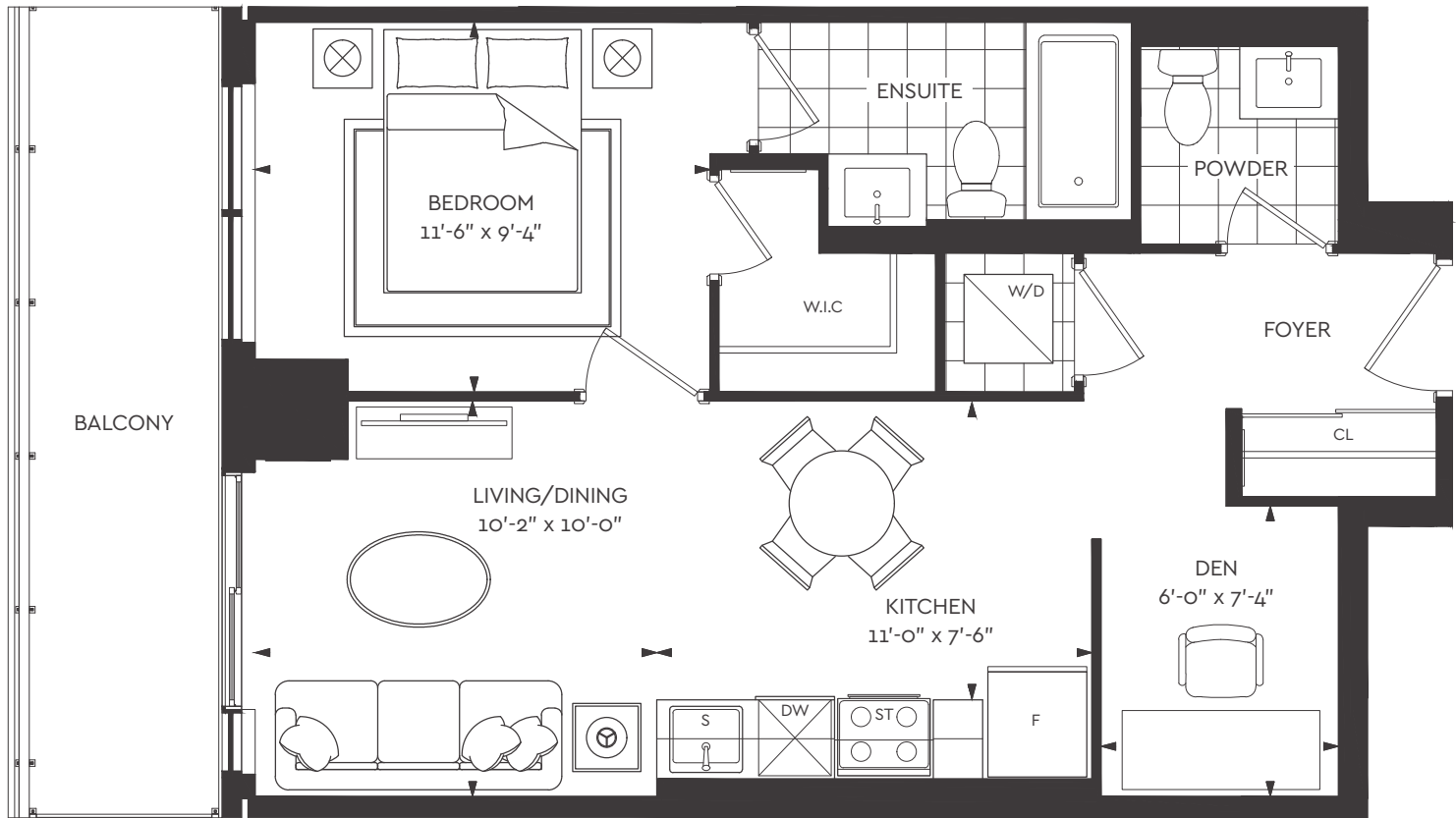

Level 19-35



1Y+D

UNIT TYPE: 1 BEDROOM + DEN
 SUITE AREA: 694 sq.ft.
 OUTDOOR AREA: 97-103 sq.ft.
 TOTAL AREA: 791-797 sq.ft.

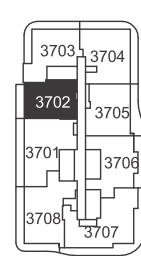
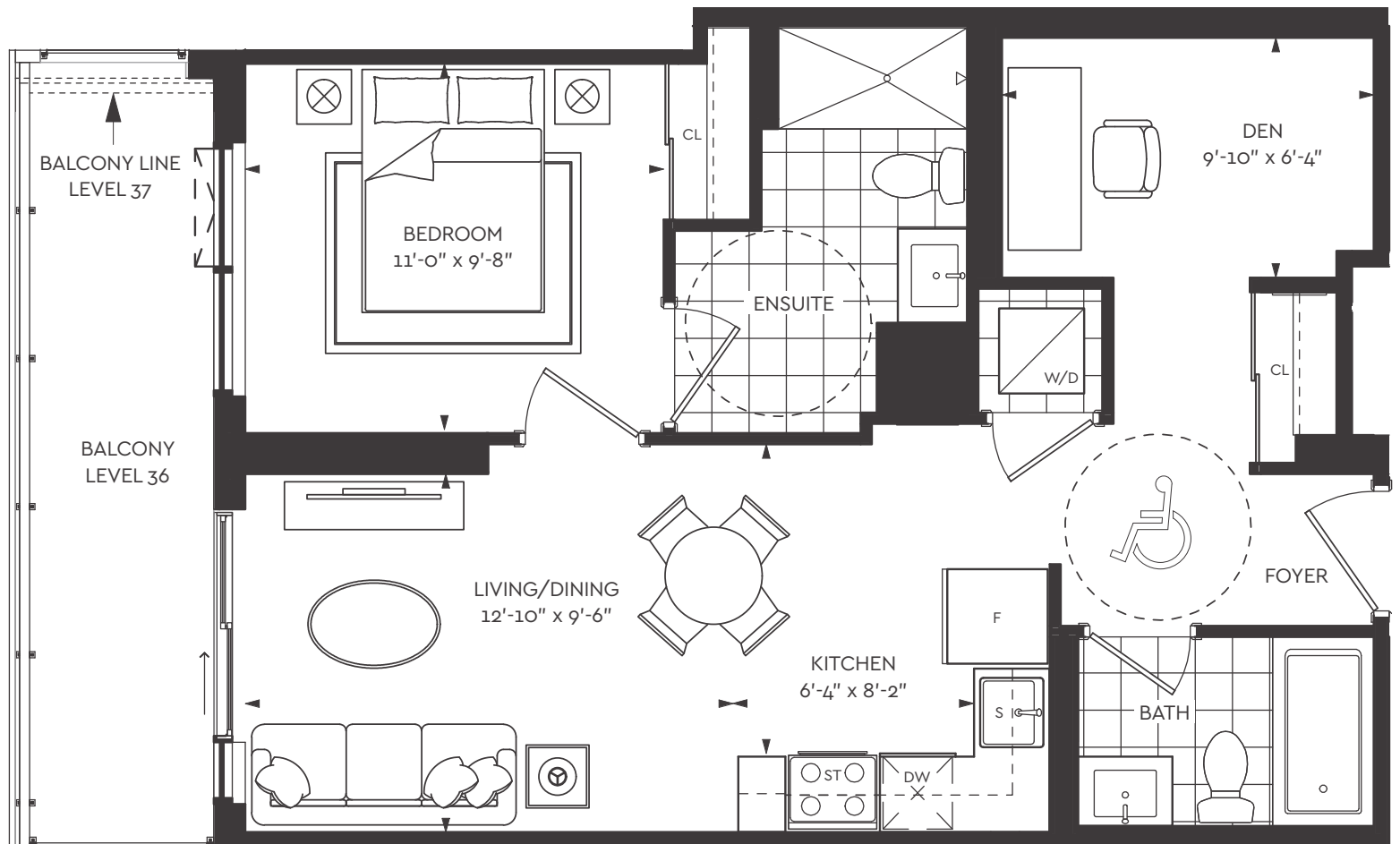

Level 37

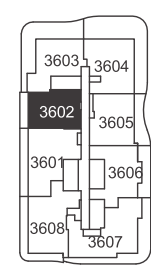

Level 36



1Z+D

UNIT TYPE: 1 BEDROOM + DEN
 SUITE AREA: 661 sq.ft.
 OUTDOOR AREA: 85-138 sq.ft.
 TOTAL AREA: 746-799 sq.ft.

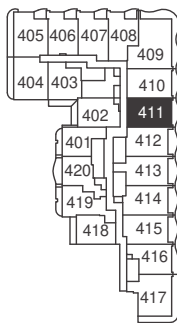
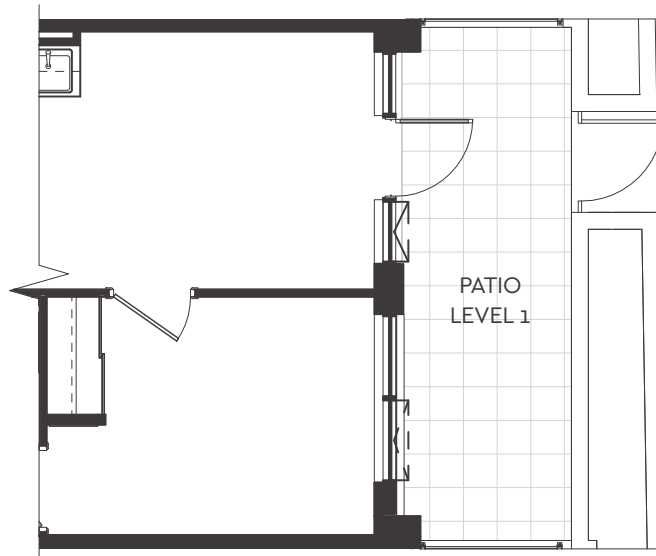
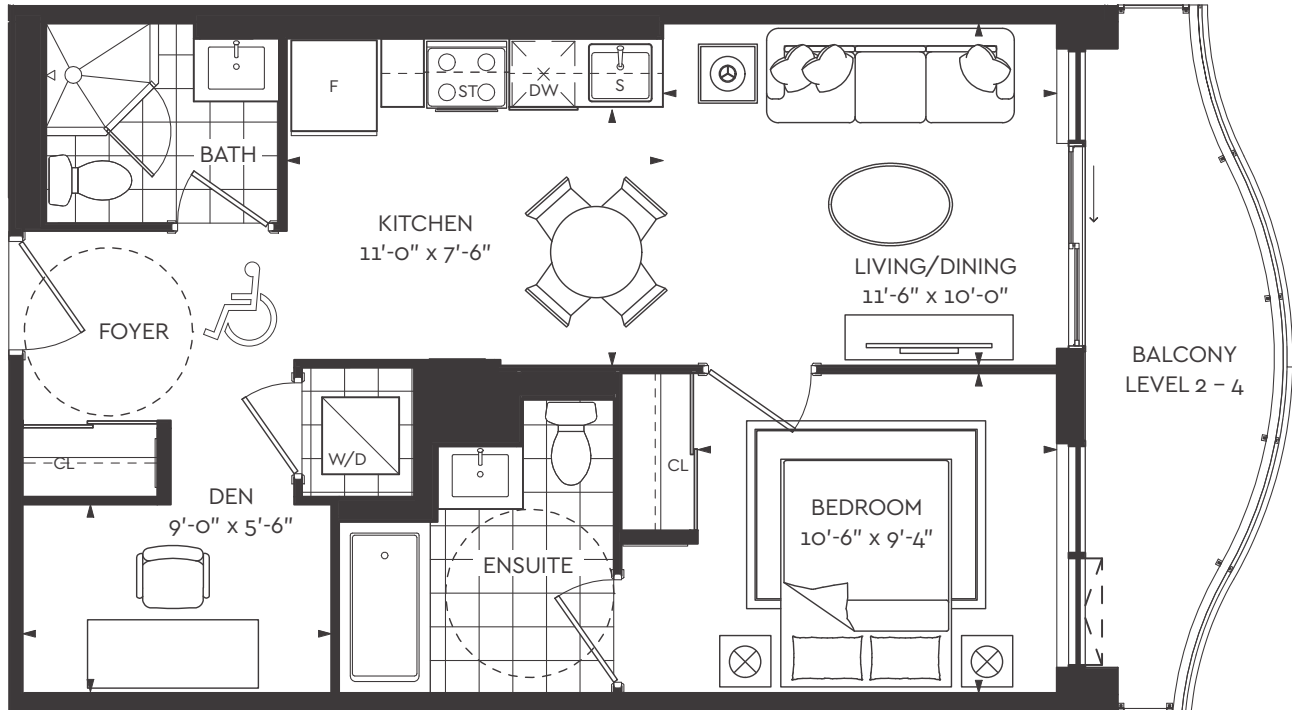

Level 4

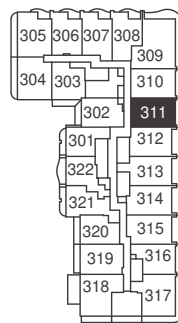

Level 3

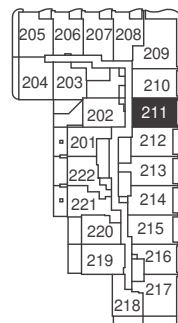

Level 2

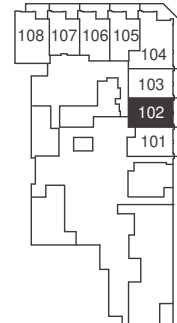

Level 1



2A

UNIT TYPE: 2 BEDROOM
 SUITE AREA: 768 sq.ft.
 OUTDOOR AREA: 154-255 sq.ft.
 TOTAL AREA: 922-1,023 sq.ft.

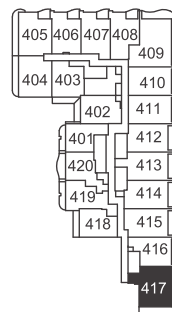

Level 4

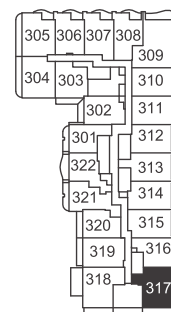

Level 3

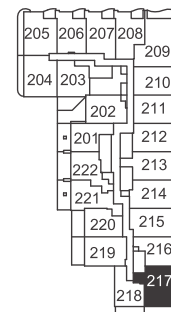

Level 2



2B

UNIT TYPE: 2 BEDROOM
 SUITE AREA: 719 sq.ft.
 OUTDOOR AREA: 131 sq.ft.
 TOTAL AREA: 850 sq.ft.

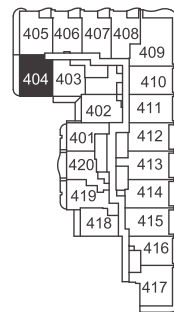
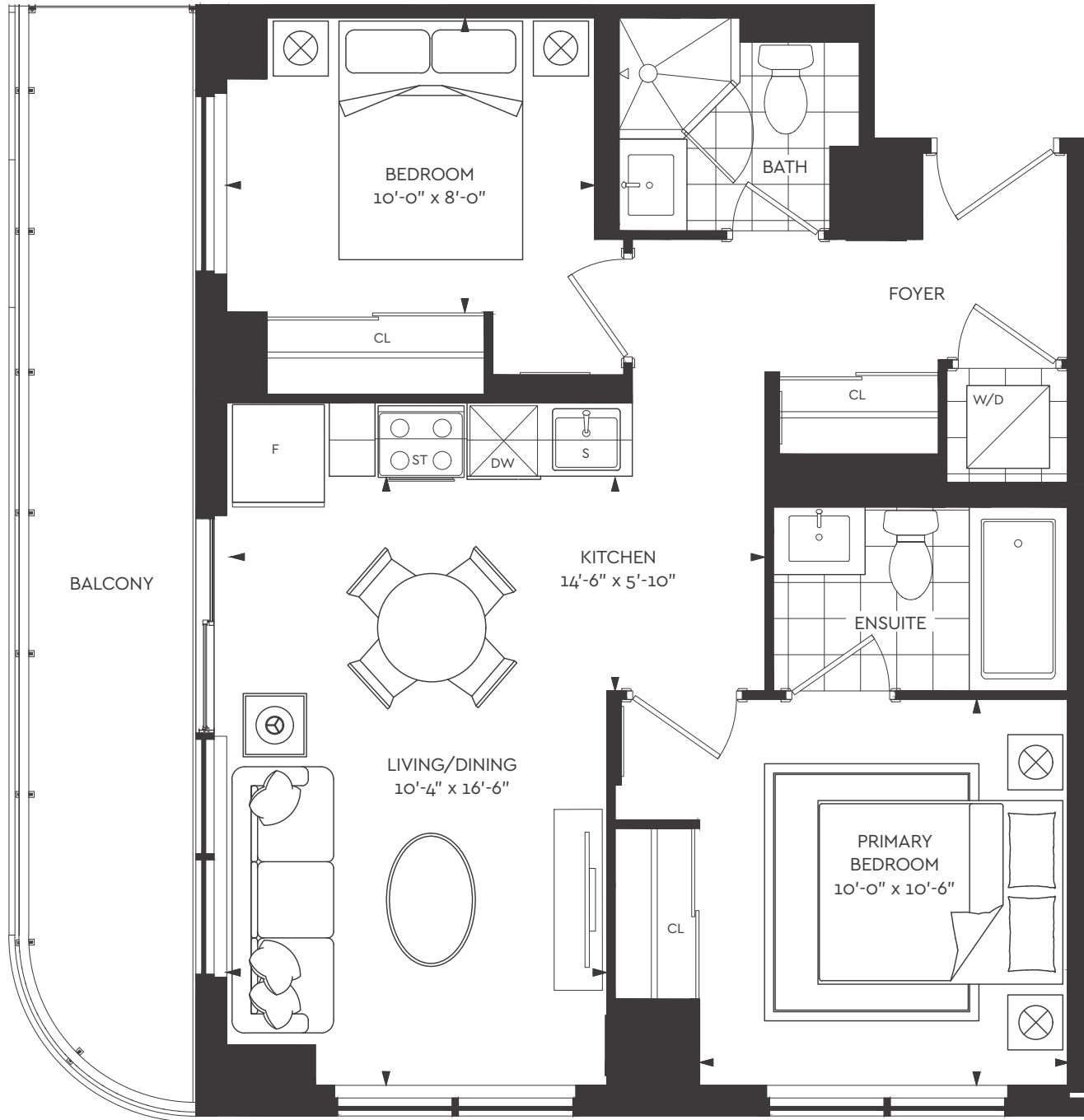

Level 4

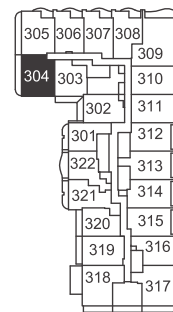

Level 3

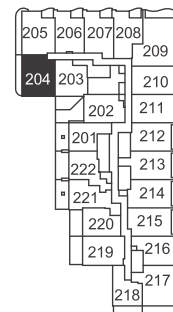

Level 2



2C

UNIT TYPE: 2 BEDROOM
 SUITE AREA: 770 sq.ft.
 OUTDOOR AREA: 278 sq.ft.
 TOTAL AREA: 1,048 sq.ft.

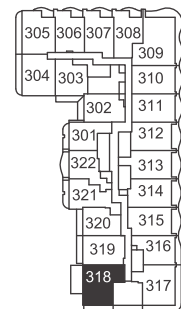
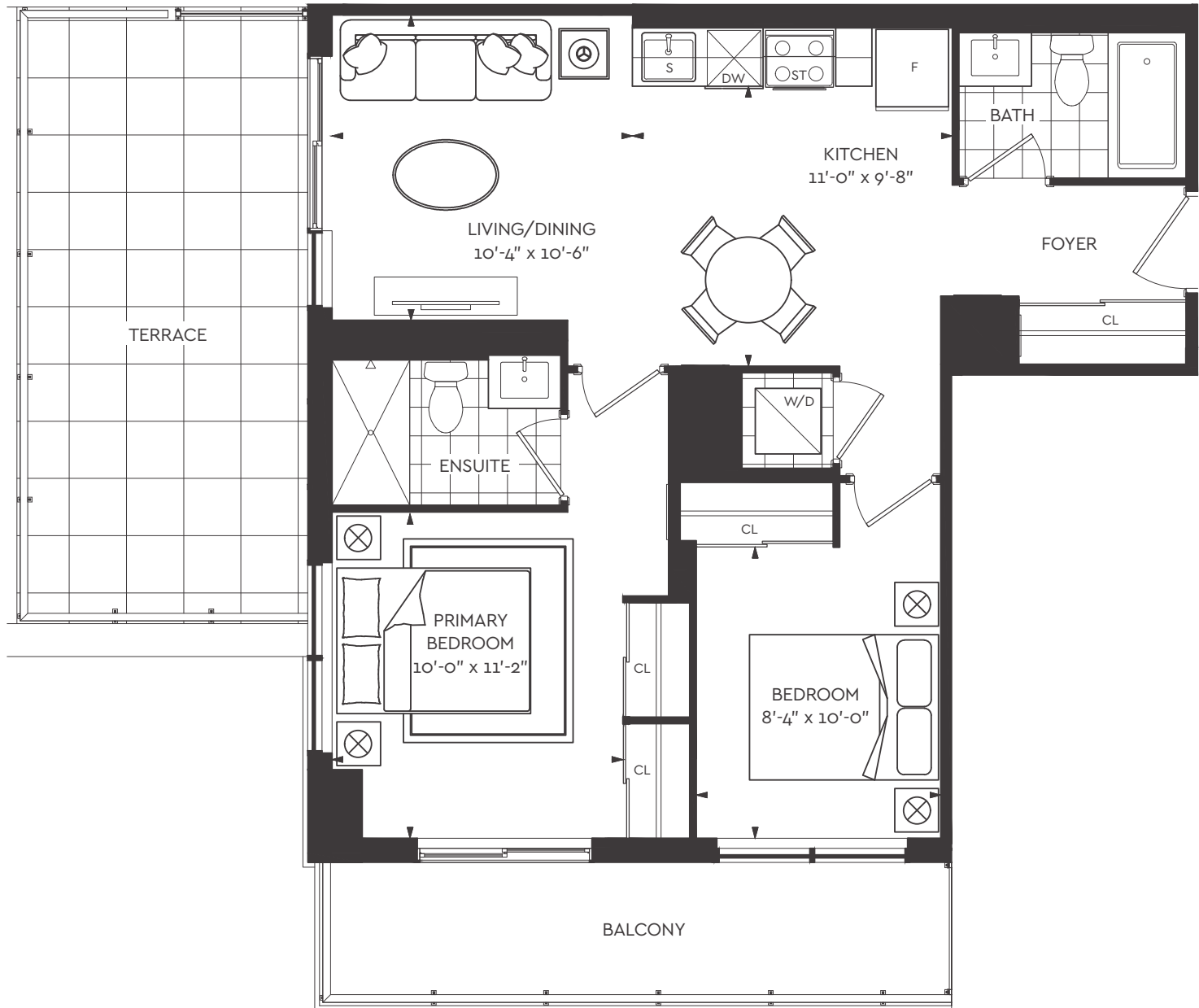

Level 3



2D

UNIT TYPE: 2 BEDROOM
 SUITE AREA: 721 sq.ft.
 OUTDOOR AREA: 198-211 sq.ft.
 TOTAL AREA: 919-832 sq.ft.

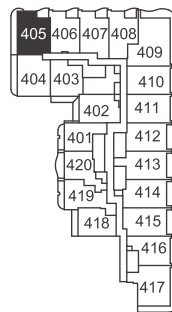
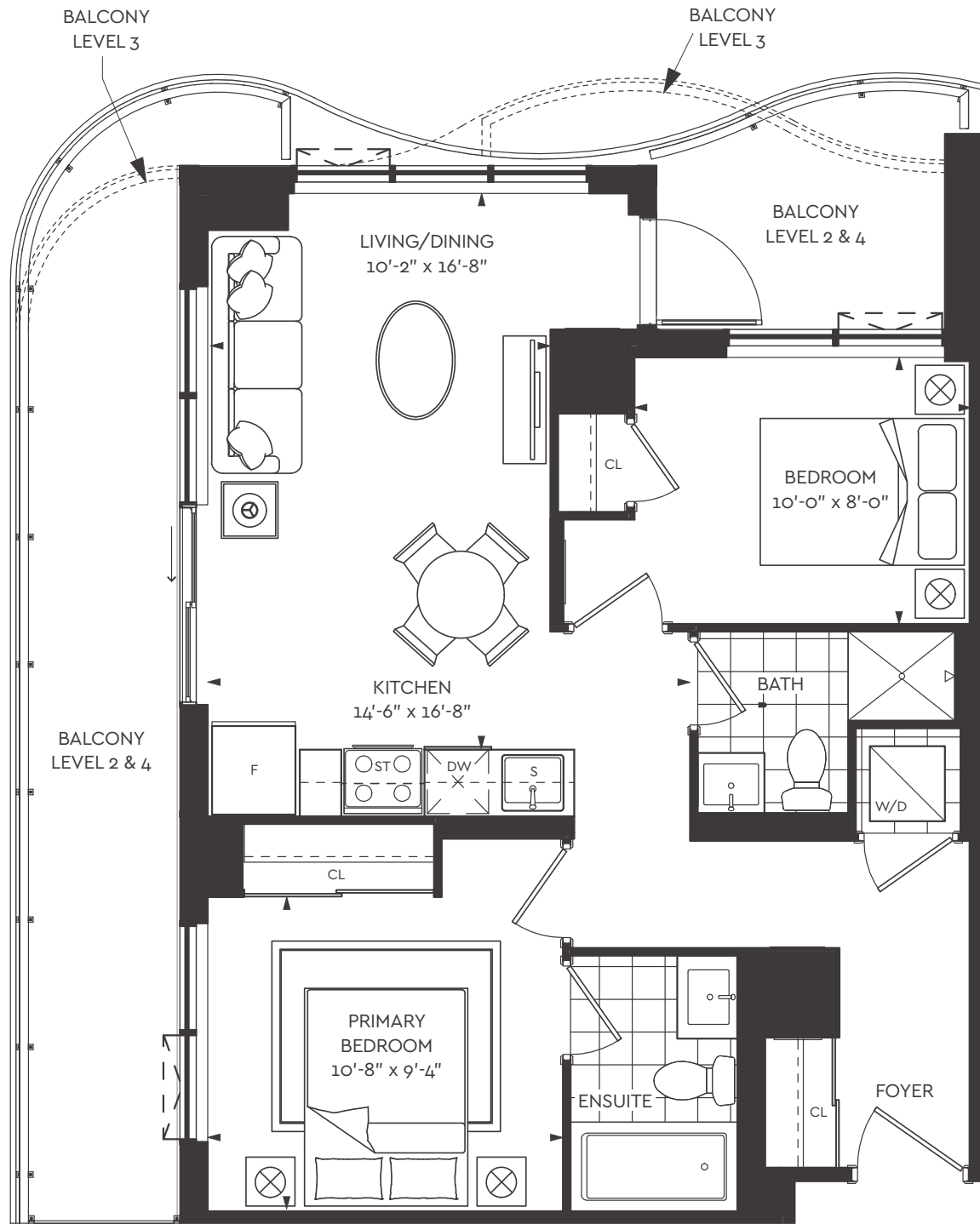

Level 4

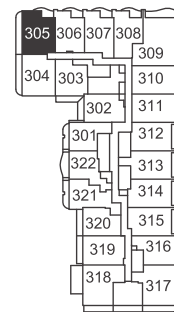

Level 3

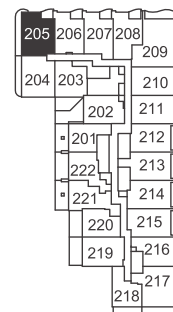

Level 2



2E

UNIT TYPE: 2 BEDROOM
 SUITE AREA: 692 sq.ft.
 OUTDOOR AREA: 347 sq.ft.
 TOTAL AREA: 1,039 sq.ft.

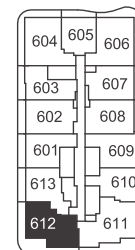
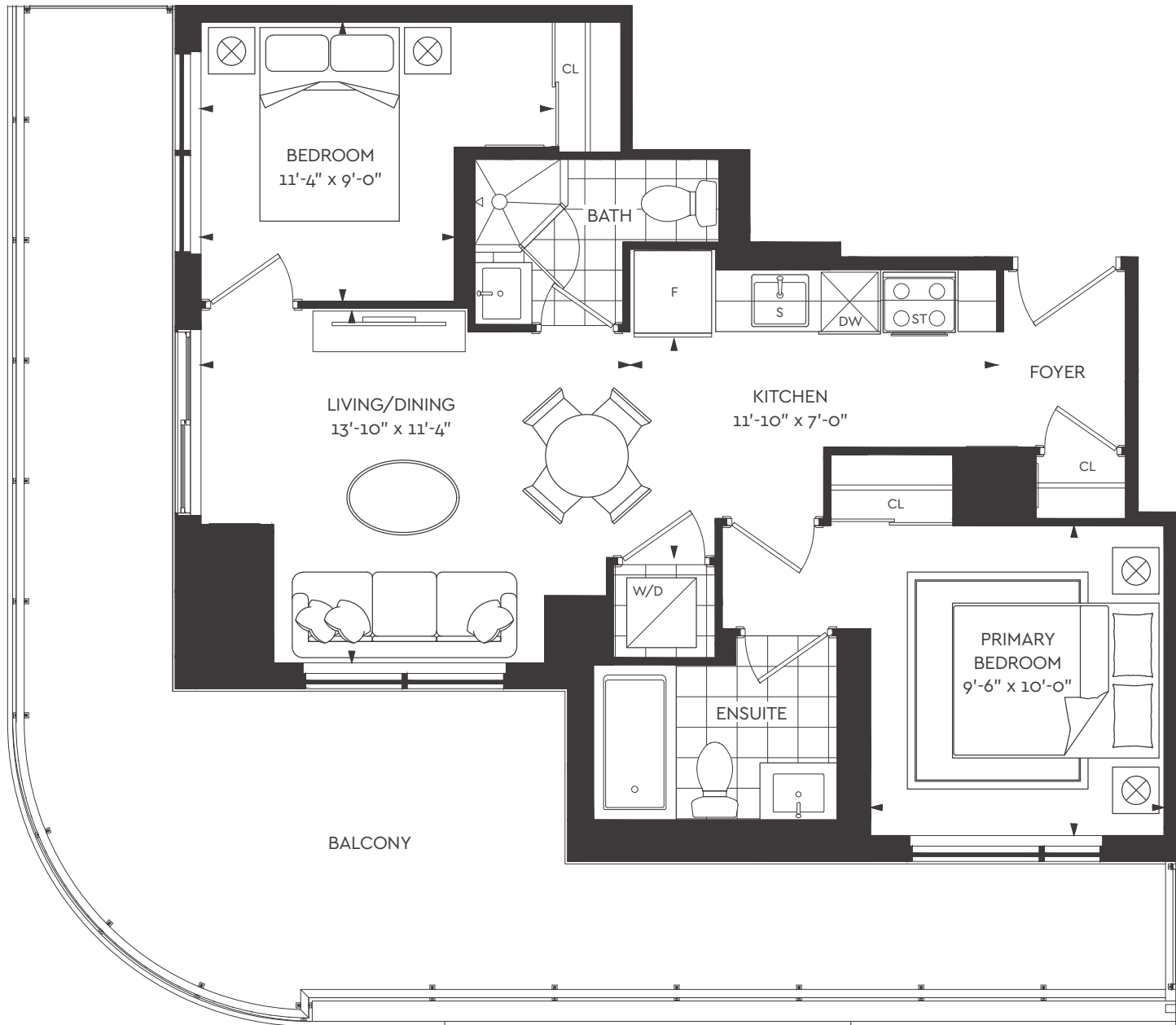

Level 6



2F

UNIT TYPE: 2 BEDROOM
 SUITE AREA: 733 sq.ft.
 OUTDOOR AREA: 220-231 sq.ft.
 TOTAL AREA: 953-964 sq.ft.

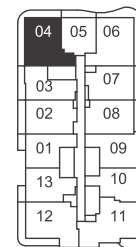

Level 7-35

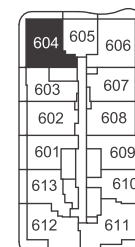

Level 6



2G

UNIT TYPE: 2 BEDROOM
 SUITE AREA: 733 sq.ft.
 OUTDOOR AREA: 271-313 sq.ft.
 TOTAL AREA: 1,004-1,046 sq.ft.

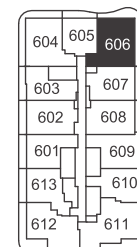
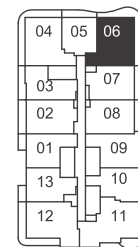
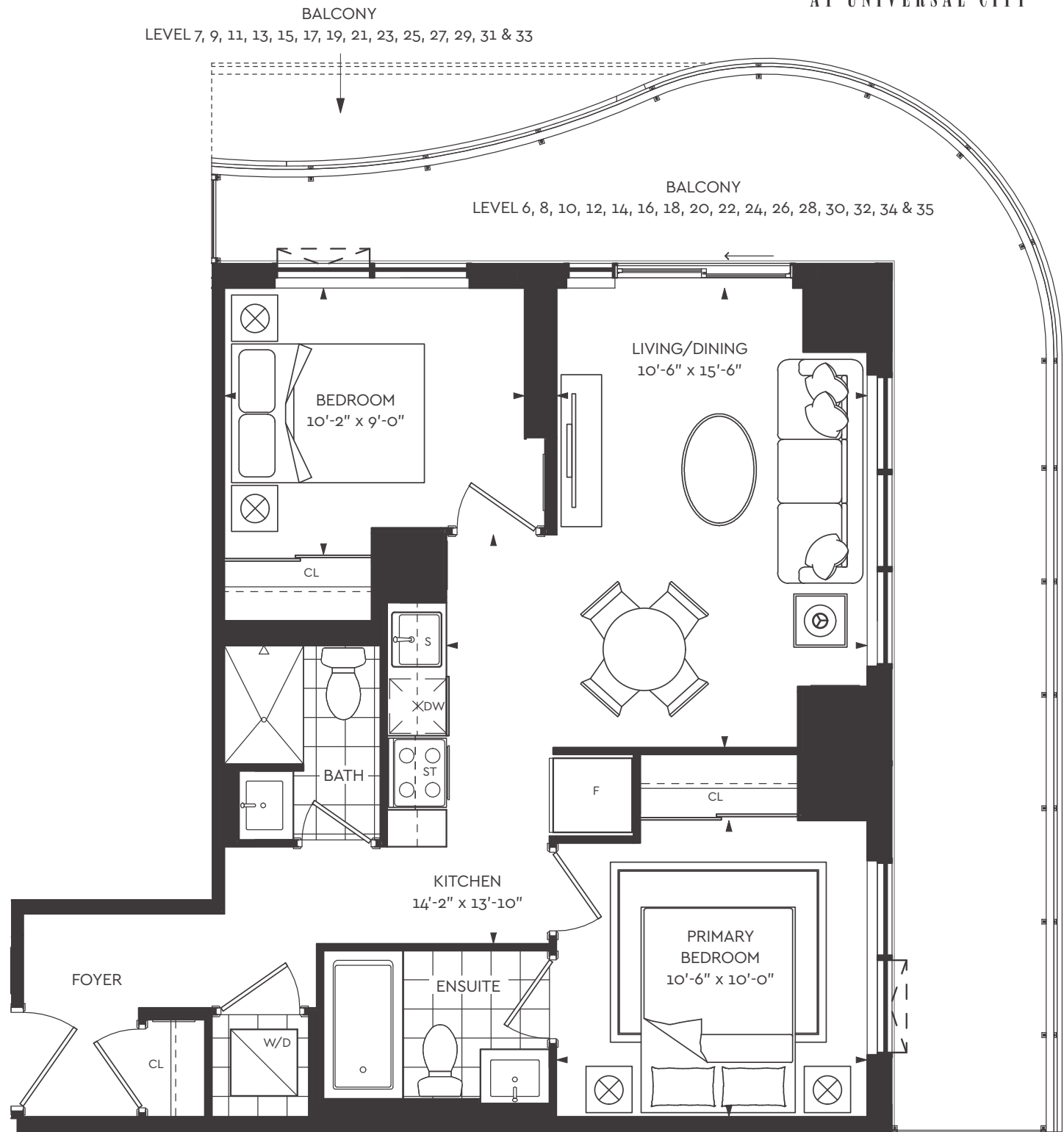

Level 7-35

Level 6



2H

UNIT TYPE: 2 BEDROOM
 SUITE AREA: 756 sq.ft.
 OUTDOOR AREA: 218 sq.ft.
 TOTAL AREA: 974 sq.ft.

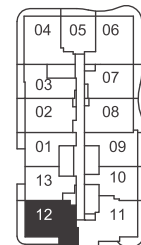
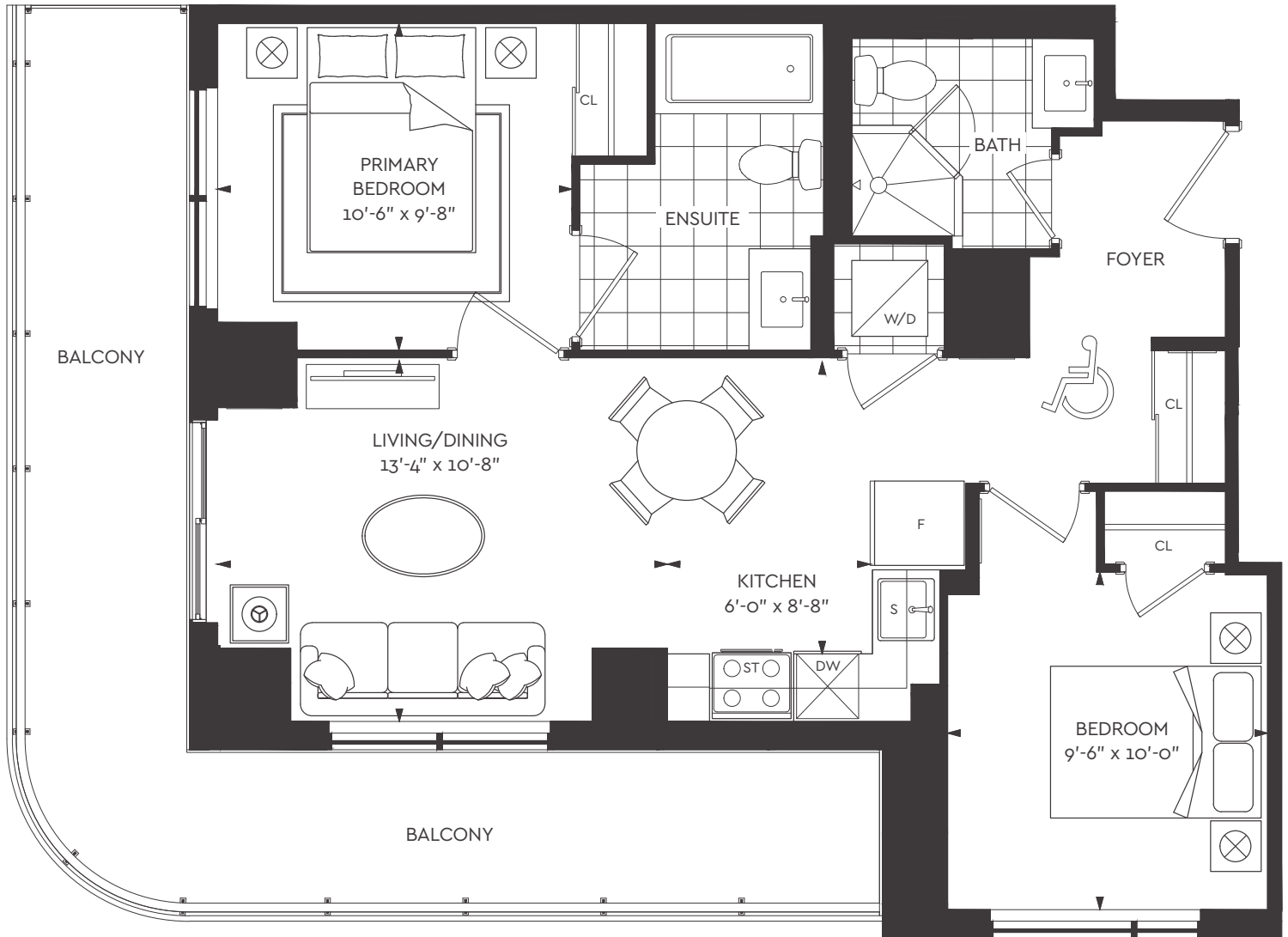

Level 7-28



2J

UNIT TYPE: 2 BEDROOM
 SUITE AREA: 812 sq.ft.
 OUTDOOR AREA: 169-204 sq.ft.
 TOTAL AREA: 981-1,016 sq.ft.

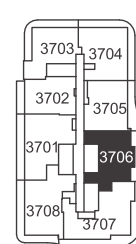
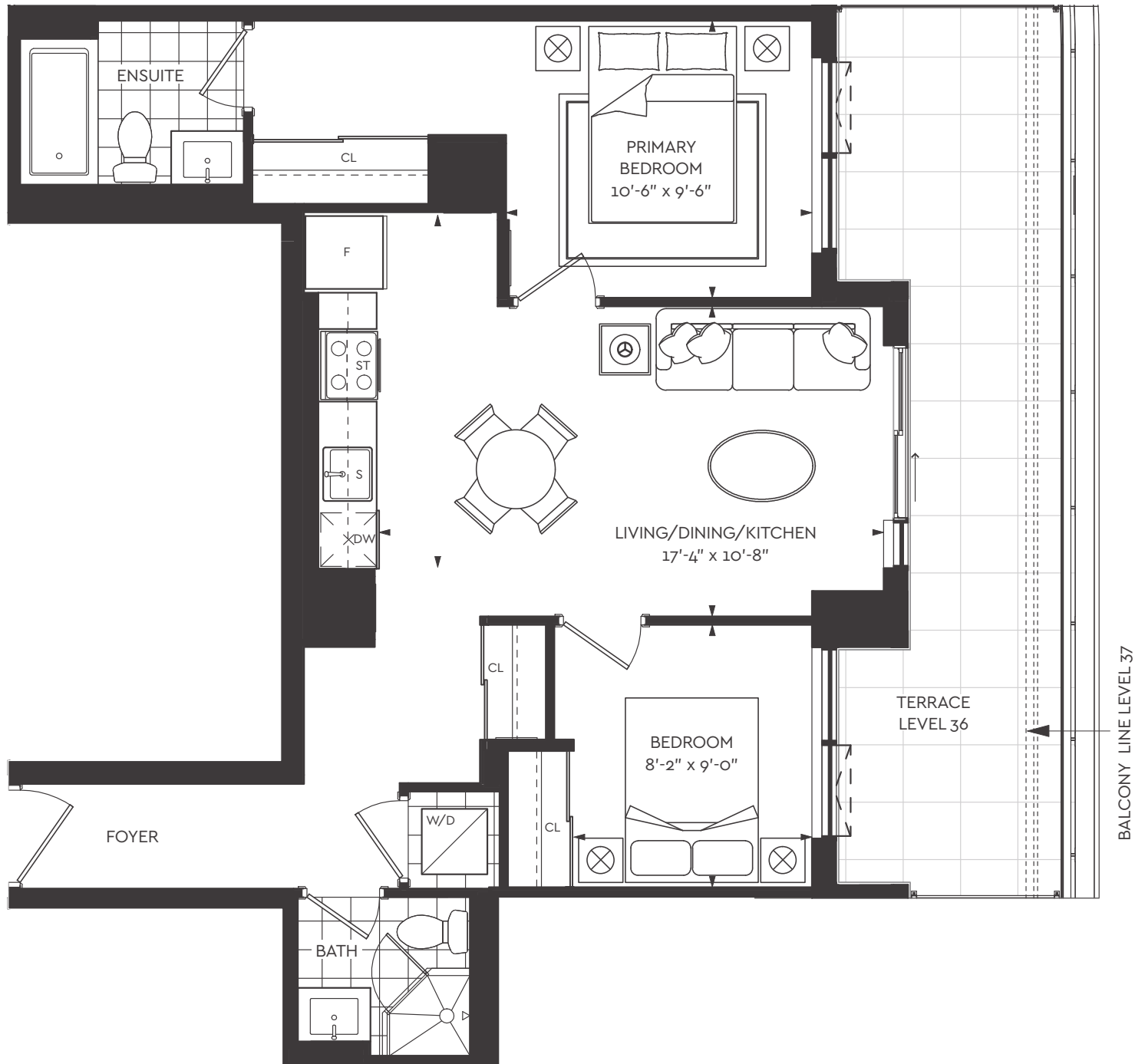

Level 37

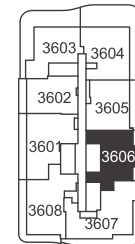

Level 36



2K

UNIT TYPE: 2 BEDROOM
 SUITE AREA: 768 sq.ft.
 OUTDOOR AREA: 228-572 sq.ft.
 TOTAL AREA: 996-1,340 sq.ft.

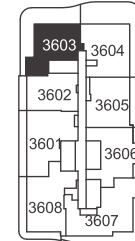
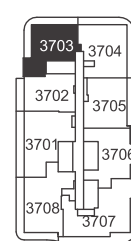
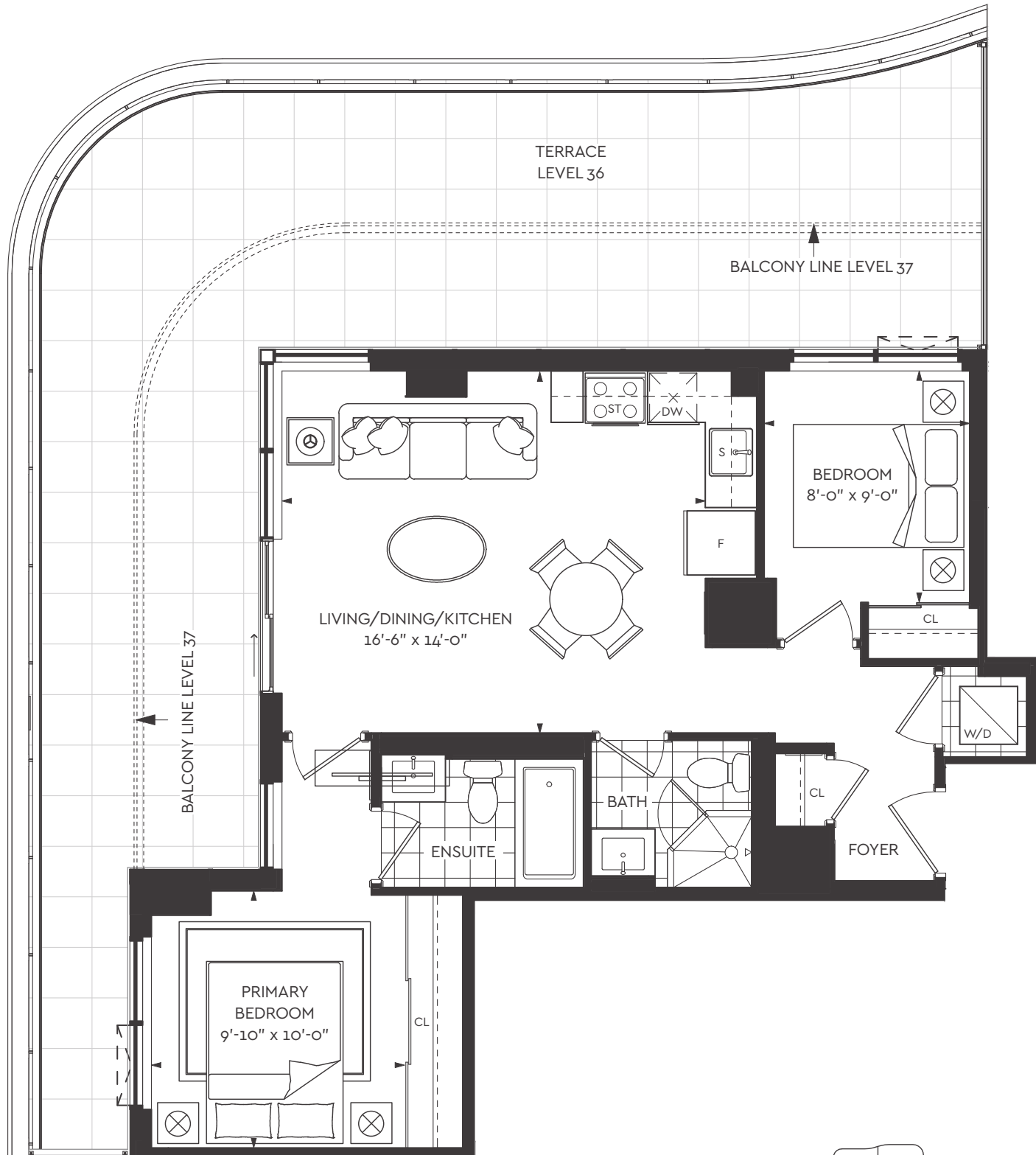

Level 37

Level 36



2L

UNIT TYPE: 2 BEDROOM
 SUITE AREA: 756 sq.ft.
 OUTDOOR AREA: 218 sq.ft.
 TOTAL AREA: 974 sq.ft.

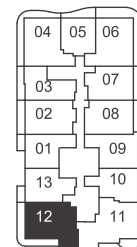
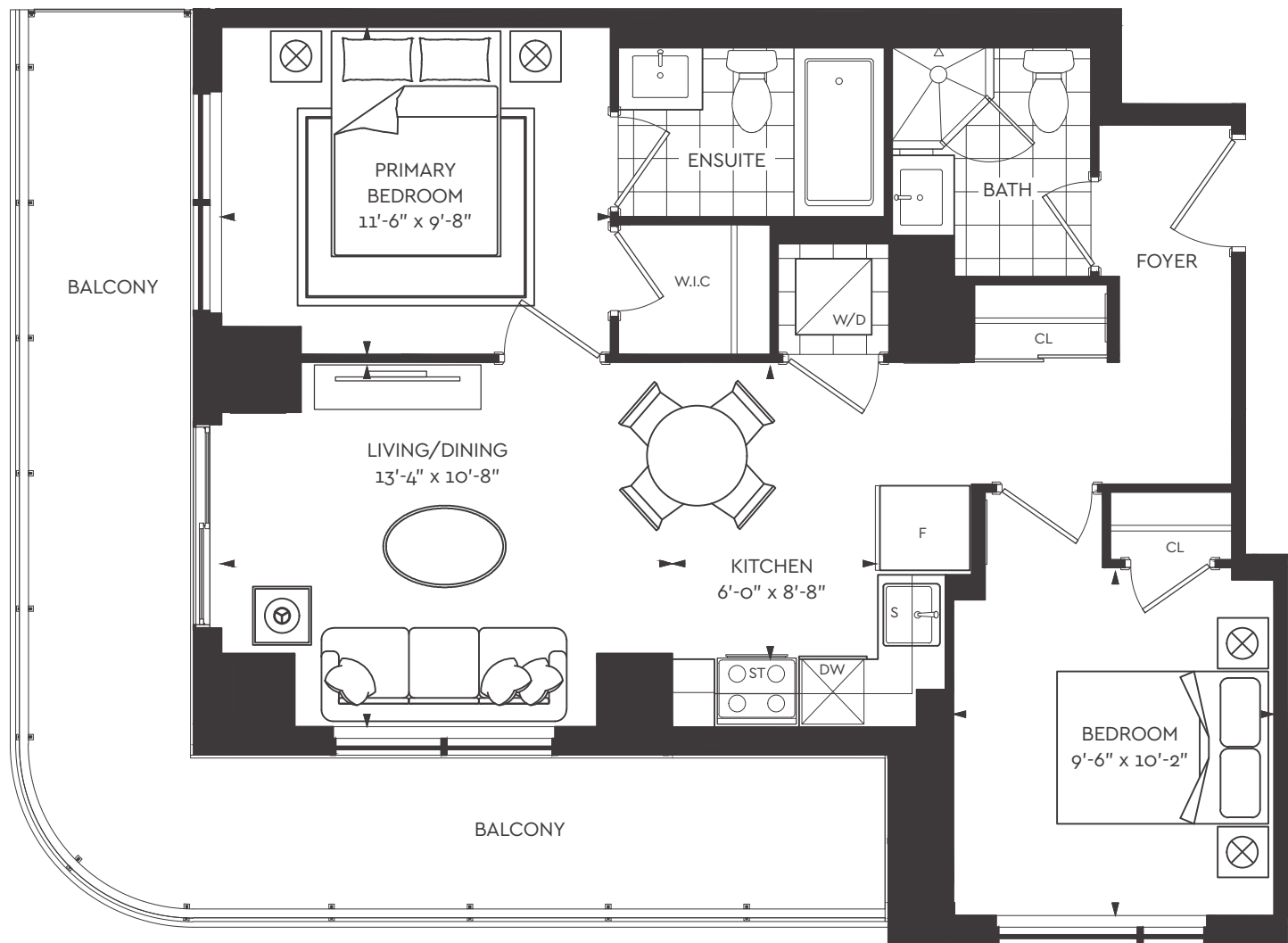

Level 29-35



2M

UNIT TYPE: 2 BEDROOM
 SUITE AREA: 811 sq.ft.
 OUTDOOR AREA: 377 sq.ft.
 TOTAL AREA: 1,188 sq.ft.

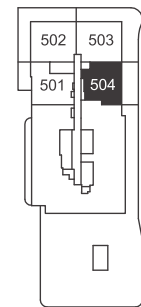
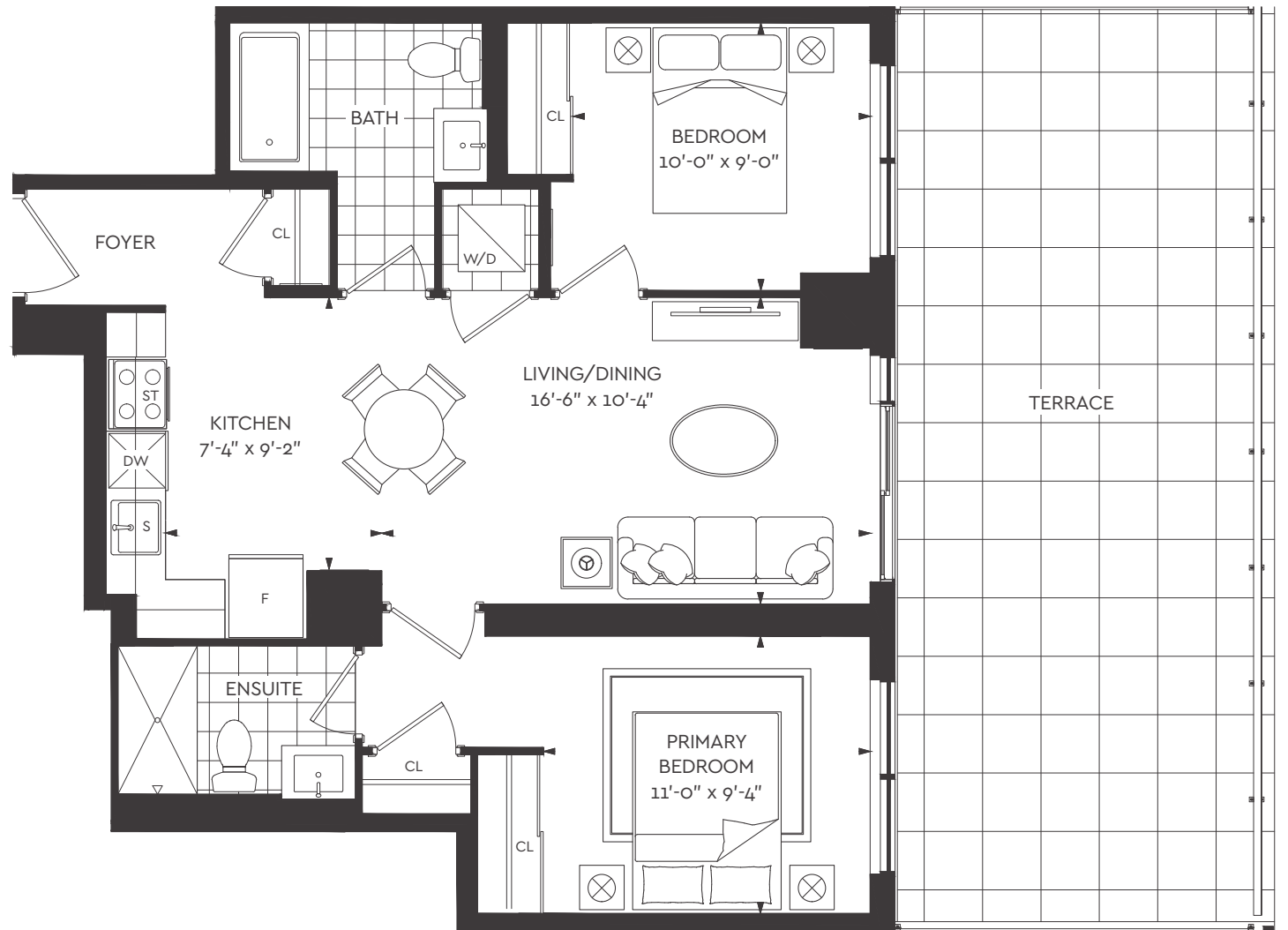

Level 5



2A+D

UNIT TYPE: 2 BEDROOM + DEN
 SUITE AREA: 851 sq.ft.
 OUTDOOR AREA: 138 sq.ft.
 TOTAL AREA: 989 sq.ft.

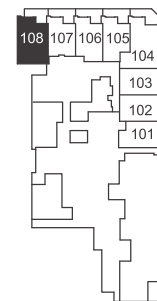
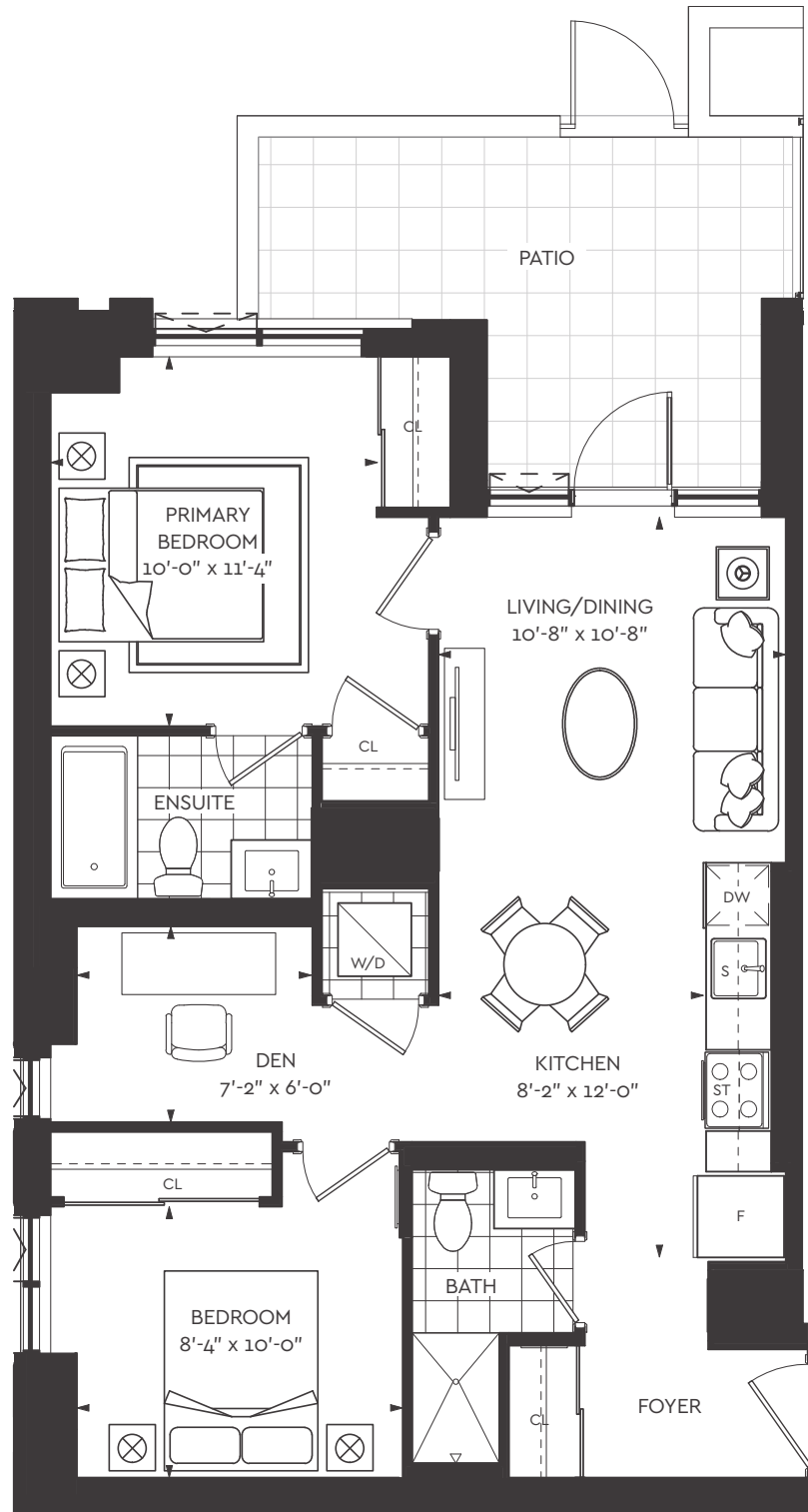

Level 1



2B+D

UNIT TYPE: 2 BEDROOM + DEN
 SUITE AREA: 821 sq.ft.
 OUTDOOR AREA: 195 sq.ft.
 TOTAL AREA: 1,016 sq.ft.

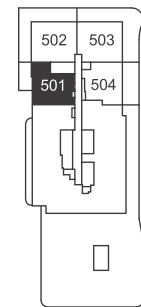
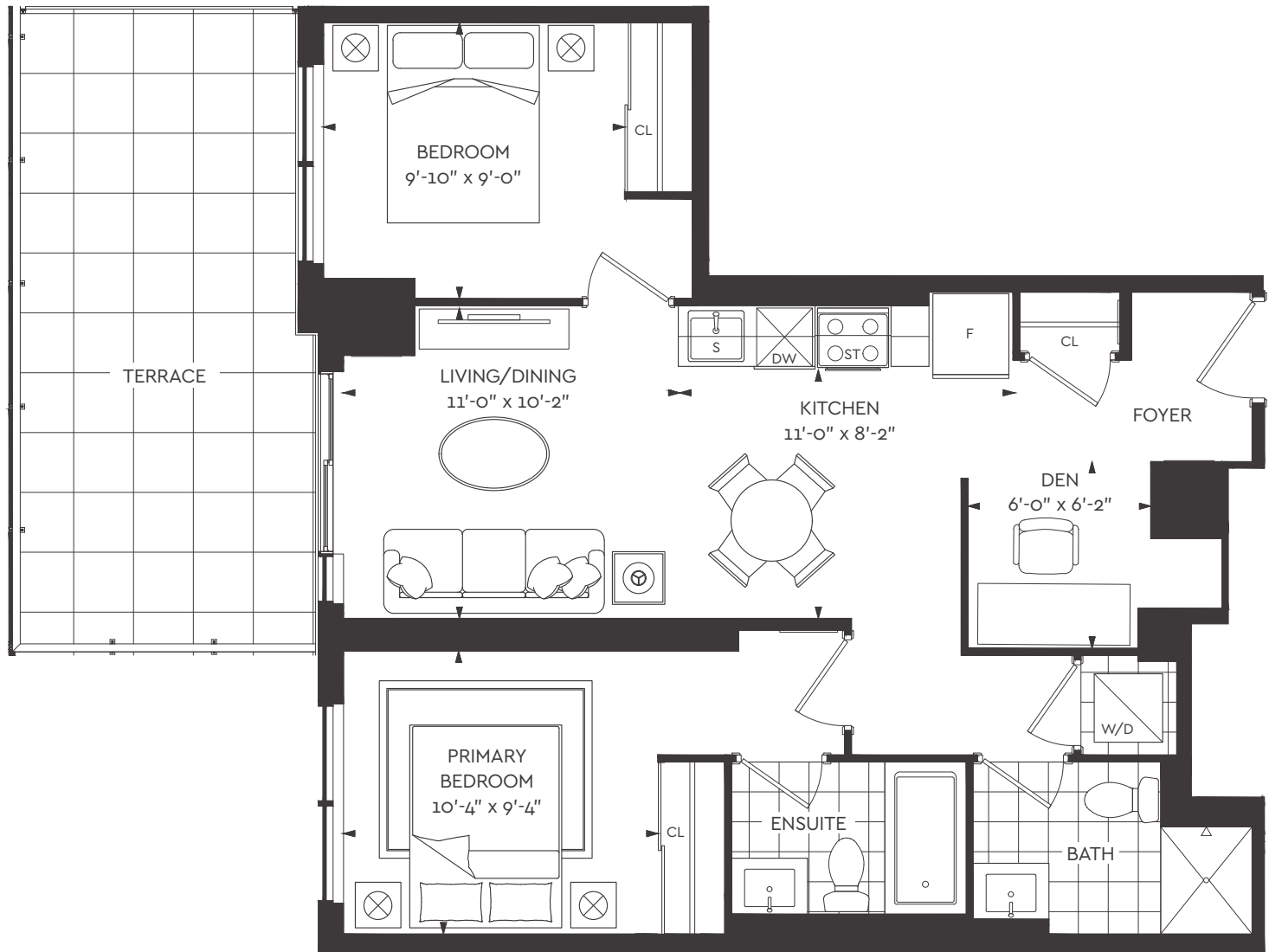

Level 5



2D+D

UNIT TYPE: 2 BEDROOM + DEN
 SUITE AREA: 805 sq.ft.
 OUTDOOR AREA: 179-367 sq.ft.
 TOTAL AREA: 984-1,172 sq.ft.

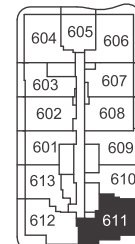
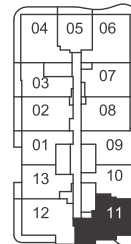
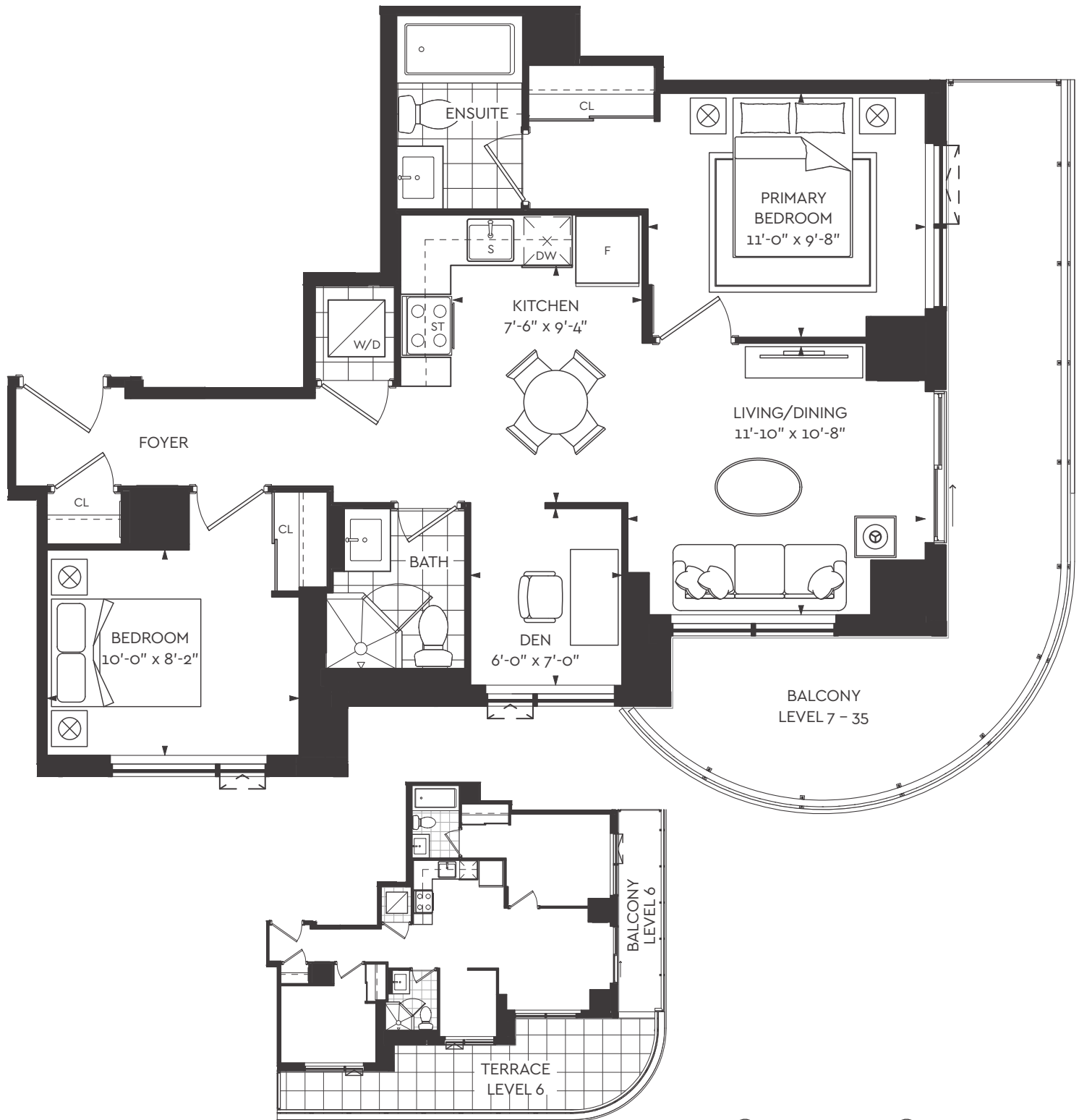

Level 7-35

Level 6



2E+D

UNIT TYPE: 2 BEDROOM + DEN
 SUITE AREA: 944 sq.ft.
 OUTDOOR AREA: 196 sq.ft.
 TOTAL AREA: 1,140 sq.ft.

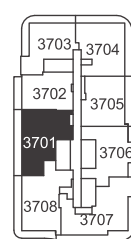
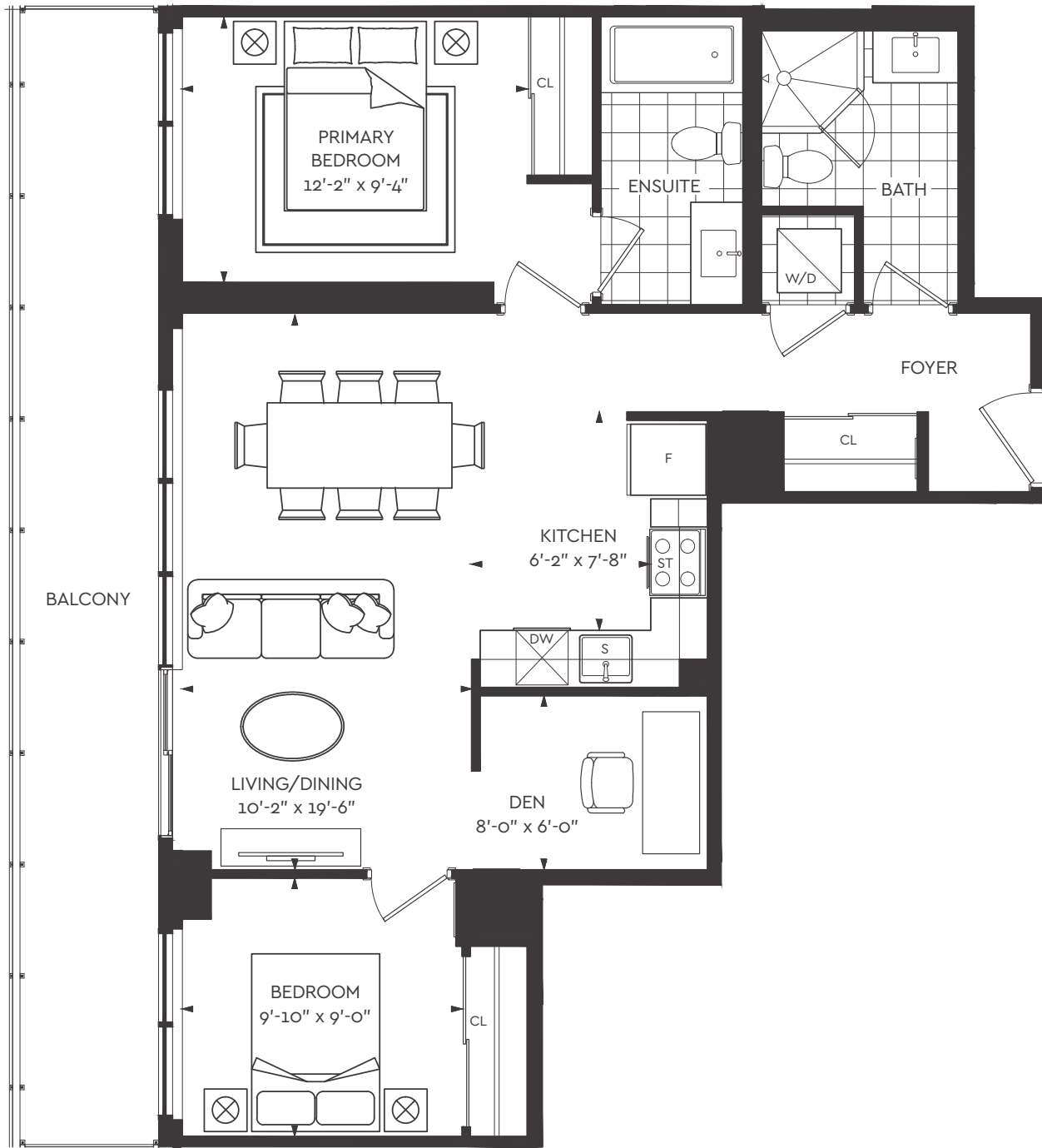

Level 37

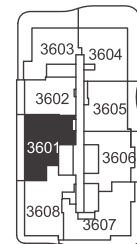

Level 36



2G+D

UNIT TYPE: 2 BEDROOM + DEN
 SUITE AREA: 785 sq.ft.
 OUTDOOR AREA: 176-207 sq.ft.
 TOTAL AREA: 961-992 sq.ft.

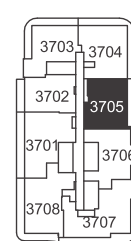
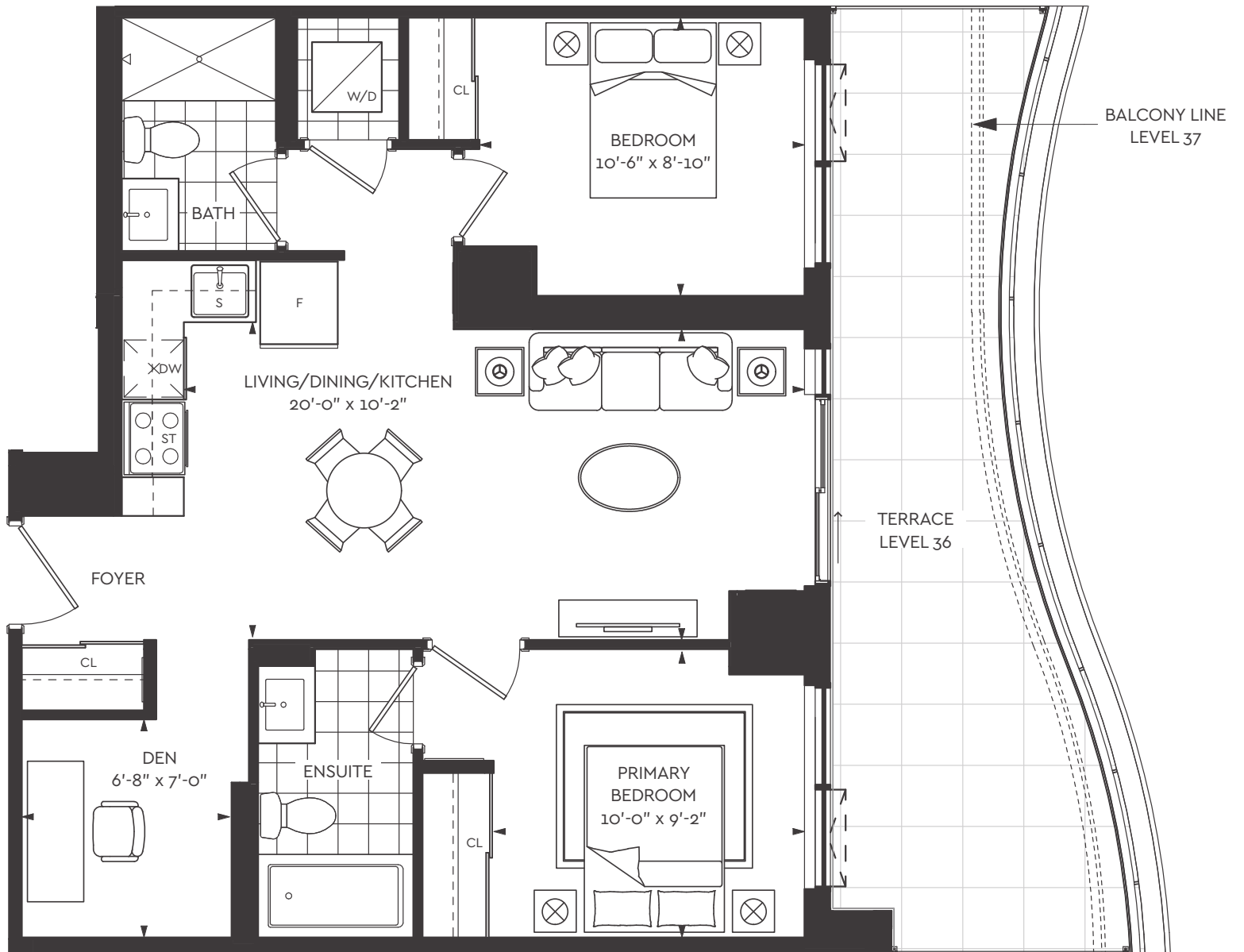

Level 37

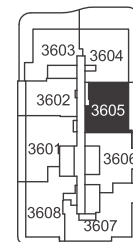

Level 36



3A

UNIT TYPE: 3 BEDROOM
 SUITE AREA: 994 sq.ft.
 OUTDOOR AREA: 396 sq.ft.
 TOTAL AREA: 1,390 sq.ft.

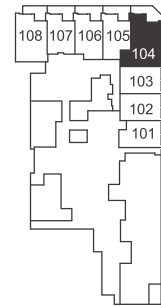
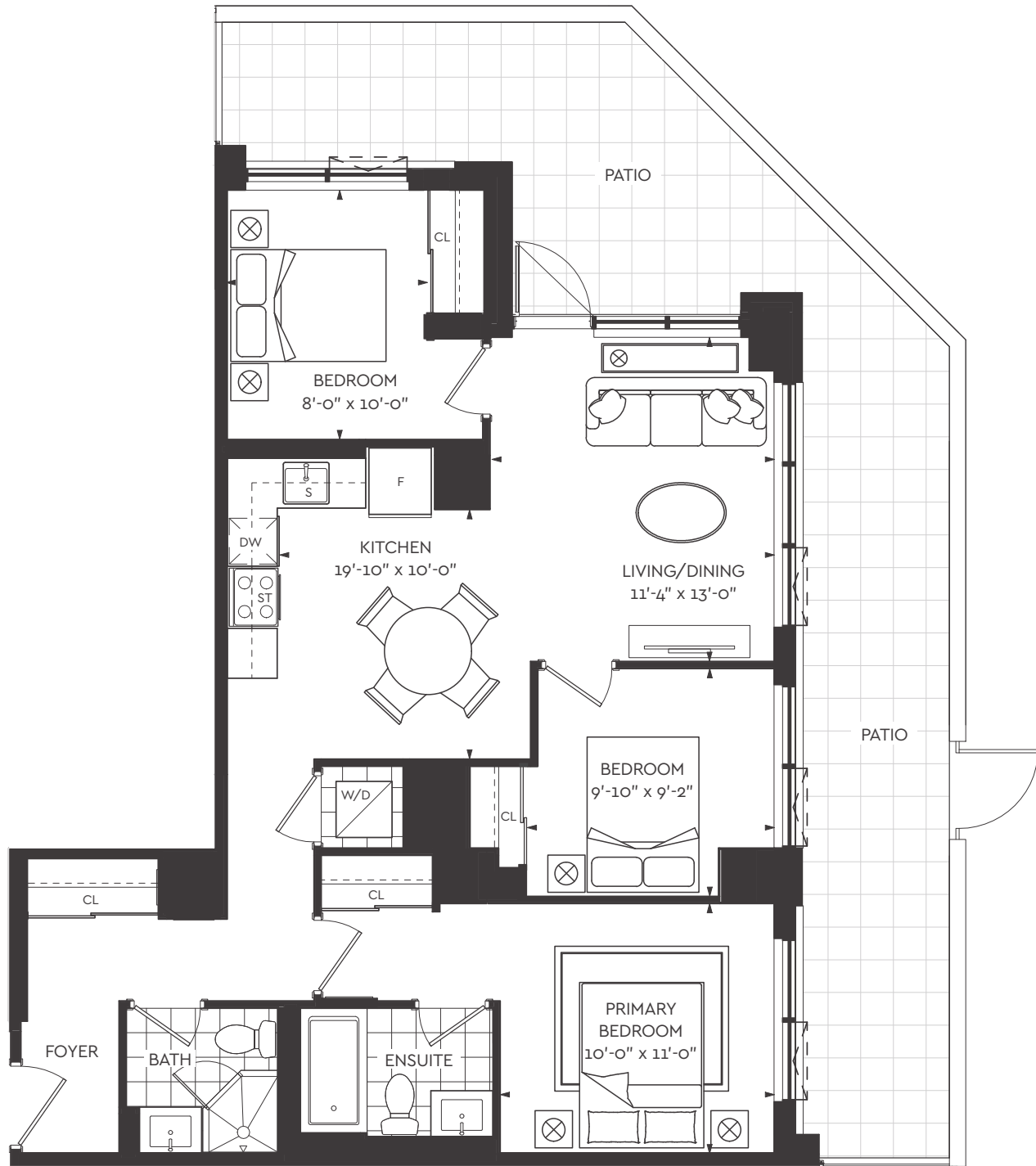

Level 1



3B

UNIT TYPE: 3 BEDROOM
 SUITE AREA: 967 sq.ft.
 OUTDOOR AREA: 291-296 sq.ft.
 TOTAL AREA: 1,258-1,263 sq.ft.

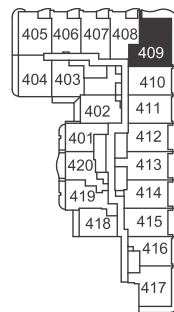
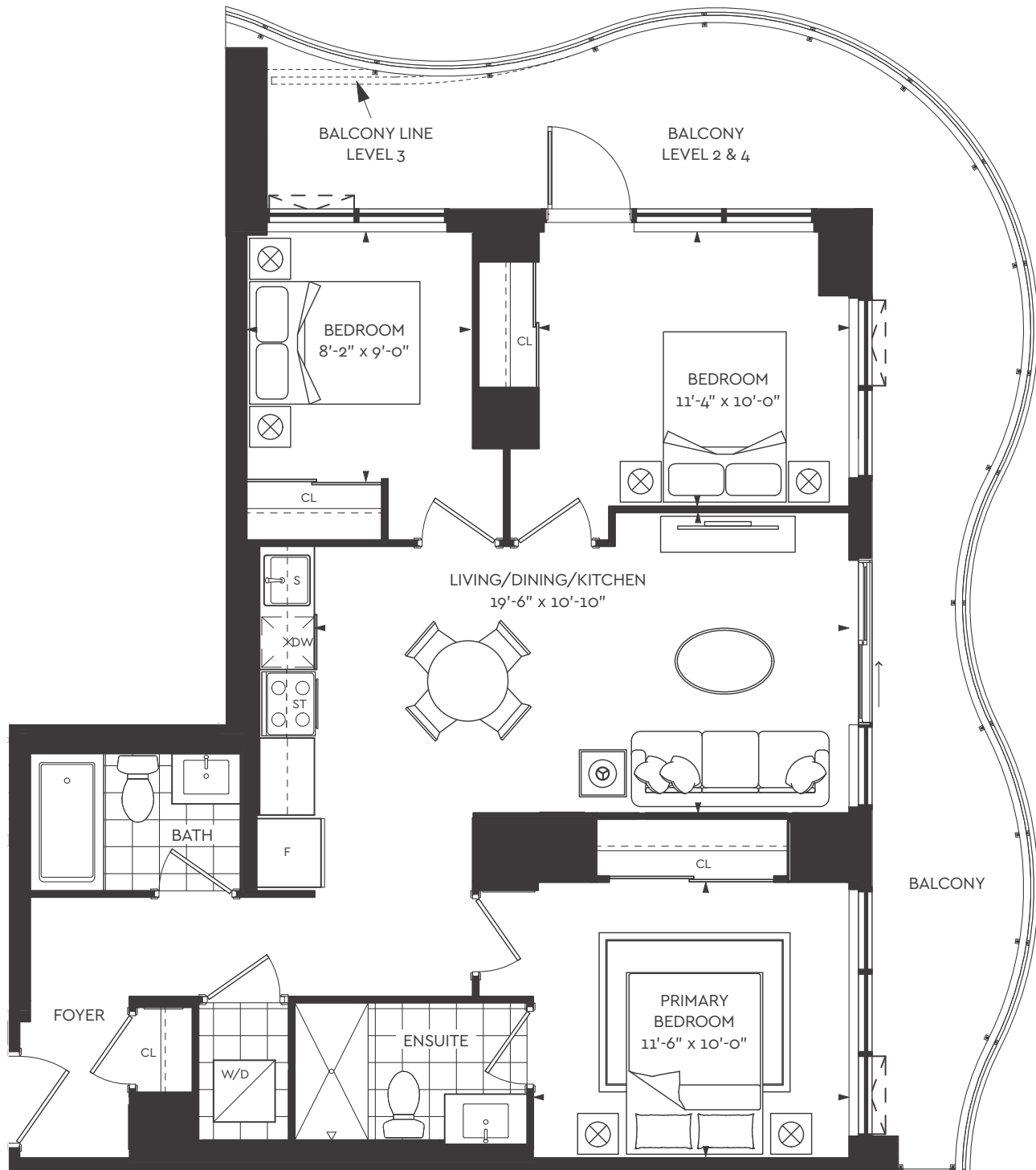

Level 4

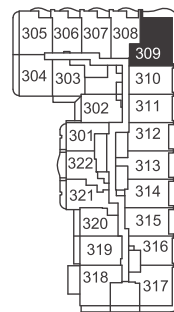

Level 3

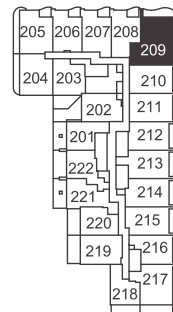

Level 2



3C

UNIT TYPE: 3 BEDROOM
 SUITE AREA: 978 sq.ft.
 OUTDOOR AREA: 701 sq.ft.
 TOTAL AREA: 1,679 sq.ft.

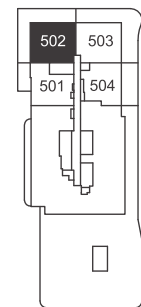
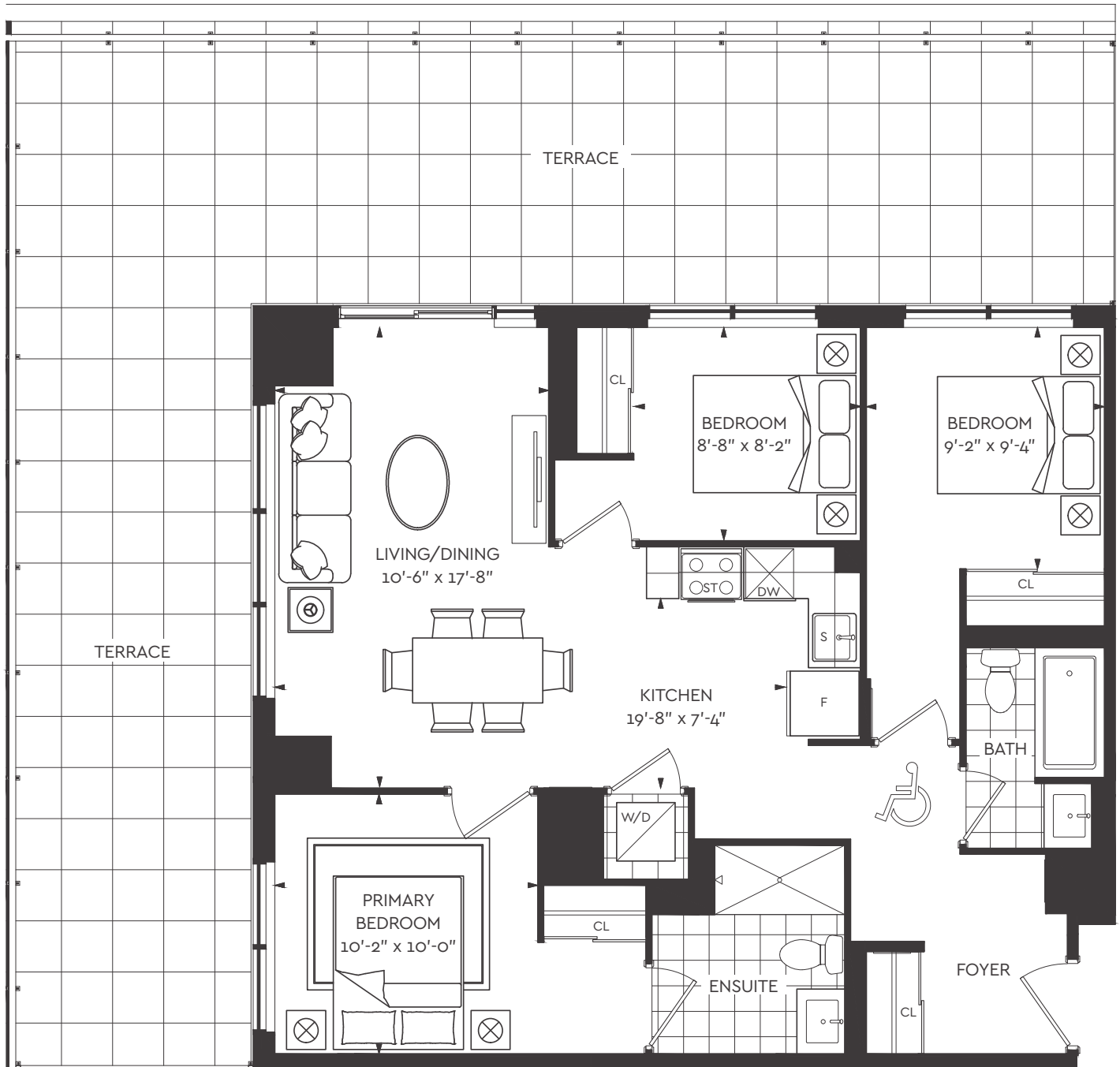

Level 5



3D

UNIT TYPE: 3 BEDROOM
 SUITE AREA: 965 sq.ft.
 OUTDOOR AREA: 844 sq.ft.
 TOTAL AREA: 1,809 sq.ft.

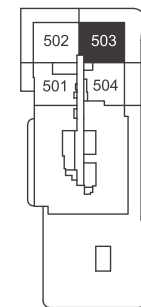
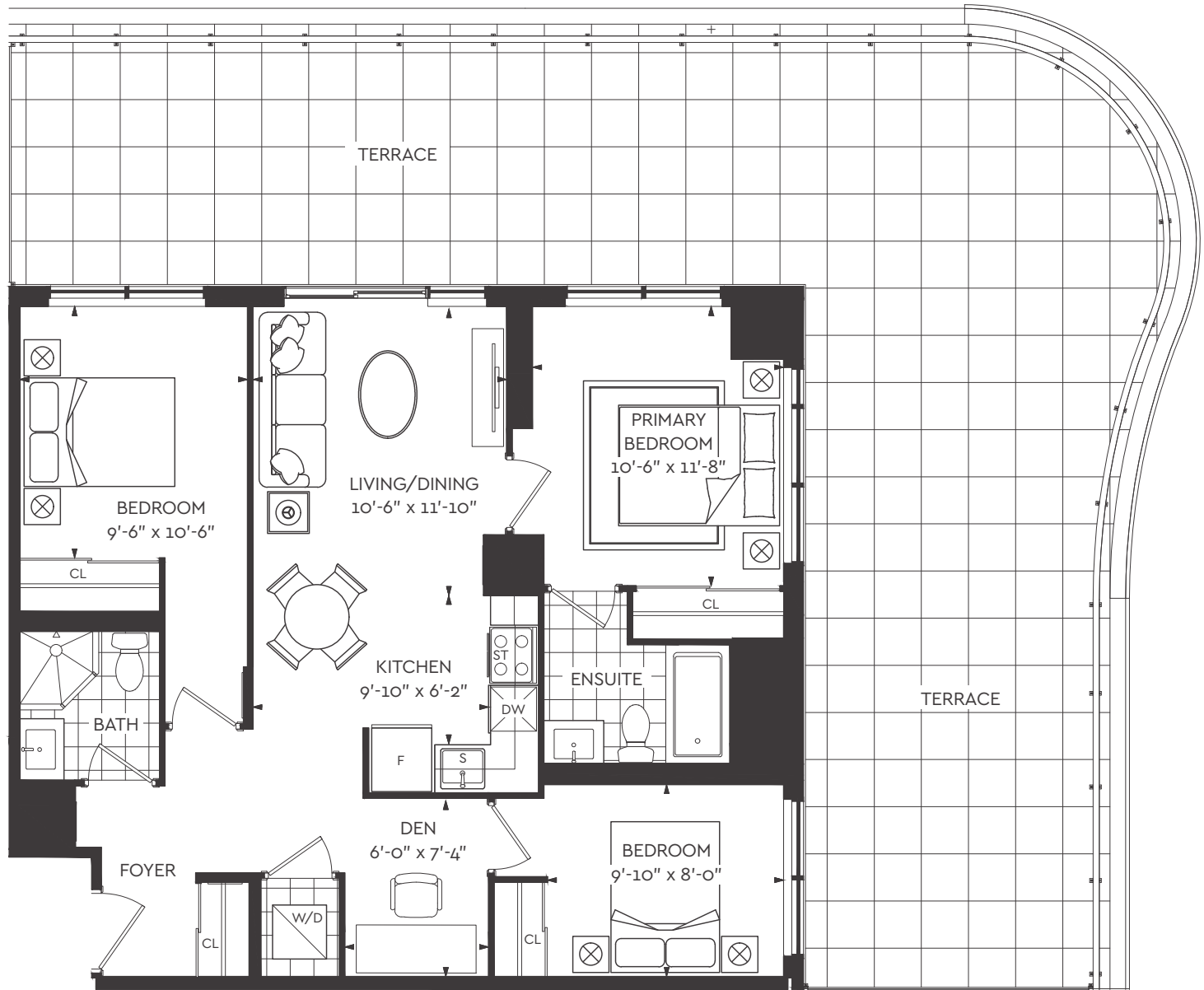

Level 5



3E

UNIT TYPE: 3 BEDROOM
 SUITE AREA: 1,026 sq.ft.
 OUTDOOR AREA: 409-441 sq.ft.
 TOTAL AREA: 1,435-1,467 sq.ft.

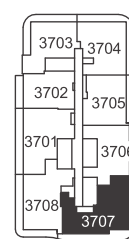
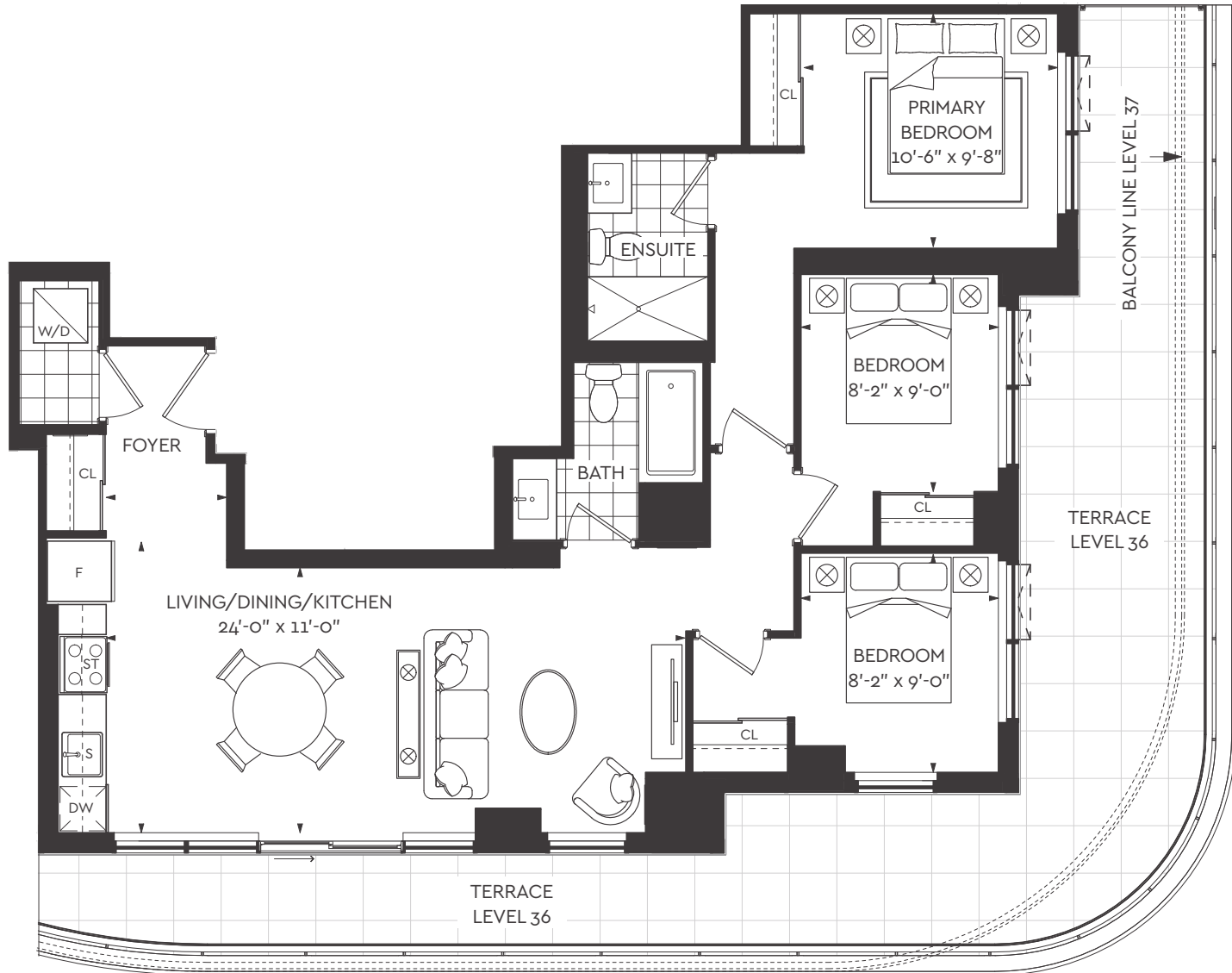

Level 37

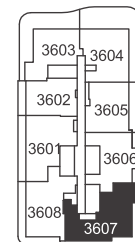

Level 36



3F

UNIT TYPE: 3 BEDROOM
 SUITE AREA: 948 sq.ft.
 OUTDOOR AREA: 276 sq.ft.
 TOTAL AREA: 1,224 sq.ft.

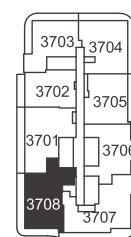
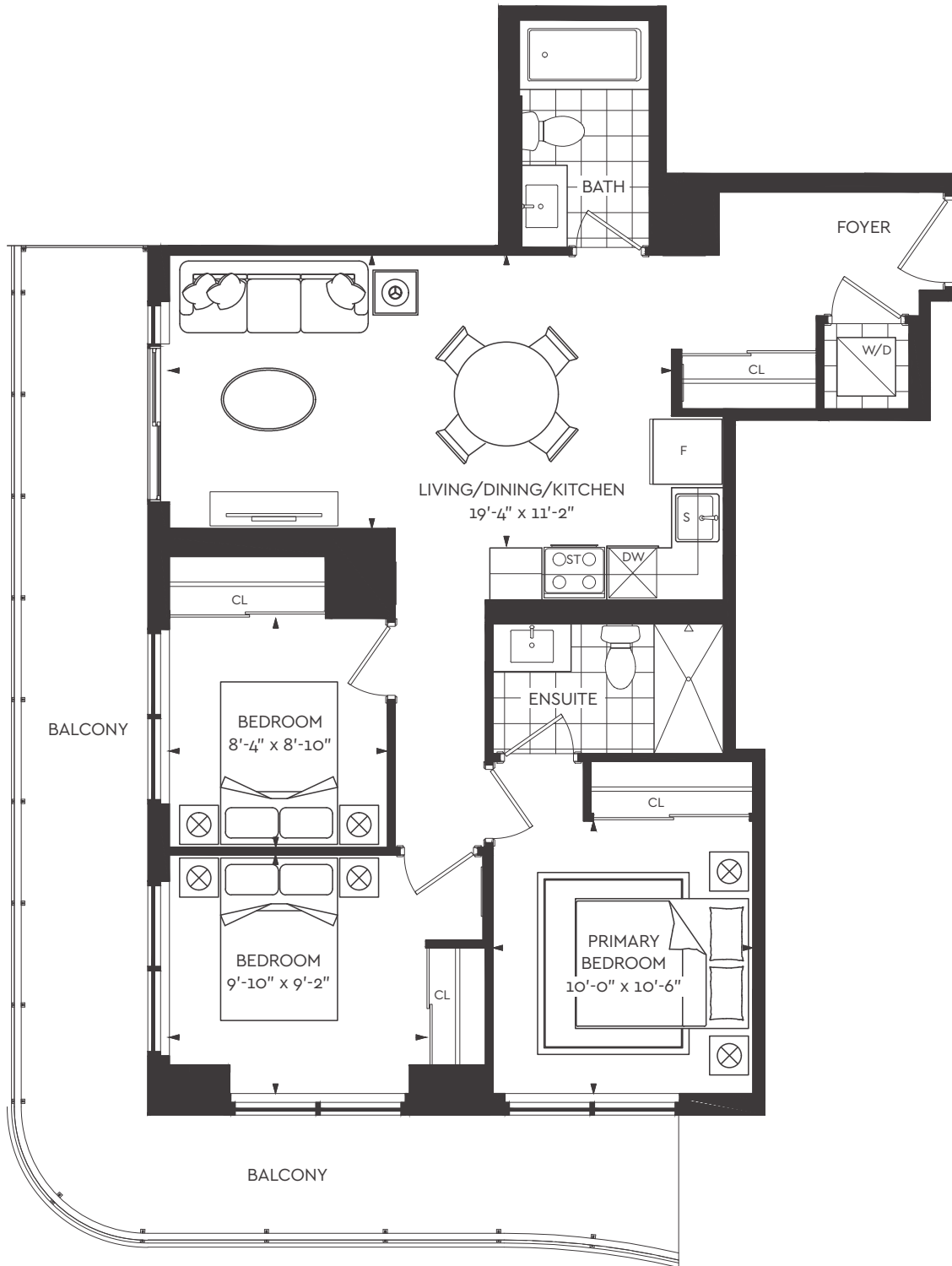

Level 37

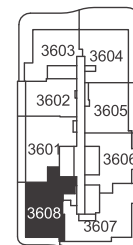

Level 36



3G

UNIT TYPE: 3 BEDROOM
 SUITE AREA: 887 sq.ft.
 OUTDOOR AREA: 284-730 sq.ft.
 TOTAL AREA: 1,171-1,617 sq.ft.

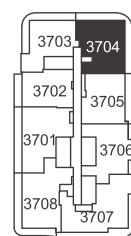
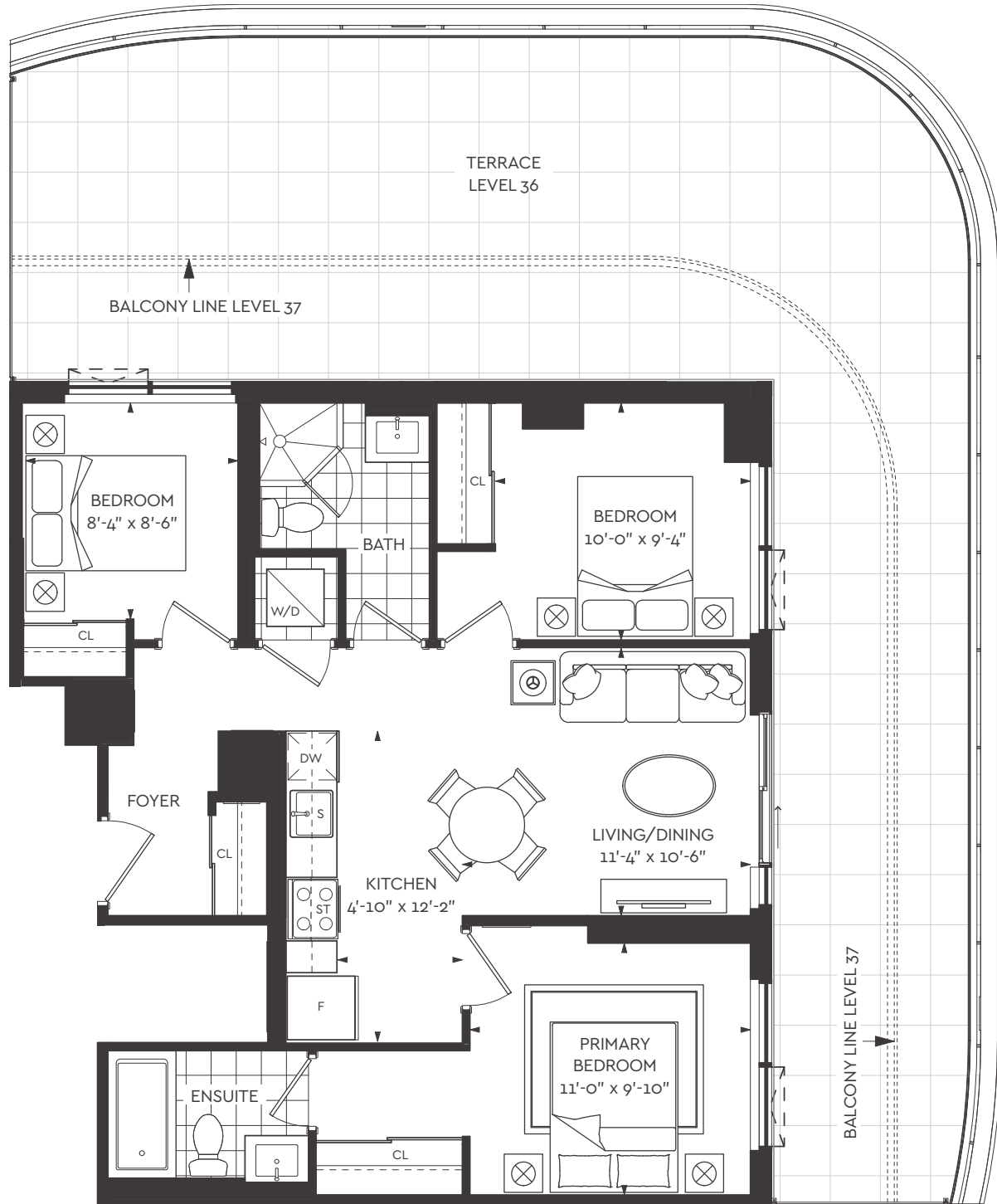

Level 37

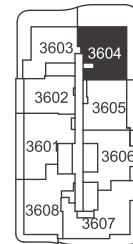

Level 36

